



***SAUDI DIESEL
EQUIPMENT***



Your Preferred Partner

CONTENTS

#	Description	Page
01	Company Overview -----	01
02	Company Overview -----	01
03	Company Overview -----	01
04	Company Overview -----	01
05	Company Overview -----	01
06	Company Overview -----	01
07	Company Overview -----	01
08	Company Overview -----	01
09	Company Overview -----	01
10	Company Overview -----	01
11	Company Overview -----	01
12	Company Overview -----	01
13	Company Overview -----	01
14	Company Overview -----	01
15	Company Overview -----	01
16	Company Overview -----	01
17	Company Overview -----	01
18	Company Overview -----	01
19	Company Overview -----	01
20	Company Overview -----	01
21	Company Overview -----	01
22	Company Overview -----	01



COMPANY OVERVIEW

Saudi Diesel Equipment Company Ltd. (SDEC)

SDEC was established in **1978**, and was formerly known as Saudi Diesel Generators Company.

Saudi Diesel Equipment Company Ltd. is part of the Abduljawad Group of Companies including **Universal Motor Agencies, Barwill Shipping, PLC Arabia,** and **Saudi Amana Construction.**

SDEC started as a local manufacturing facility to design, develop, and produce its own branded generator sets along with power related accessories, **SDEC** became a pioneer in the diesel generators industry, and was able to develop and expand its business over the years.

Today **SDEC** has expanded to include: Construction, Lifting & Concrete Equipment, Parts & Attachments, Commercial Vehicles and Equipment Rentals.

OUR PRODUCTS

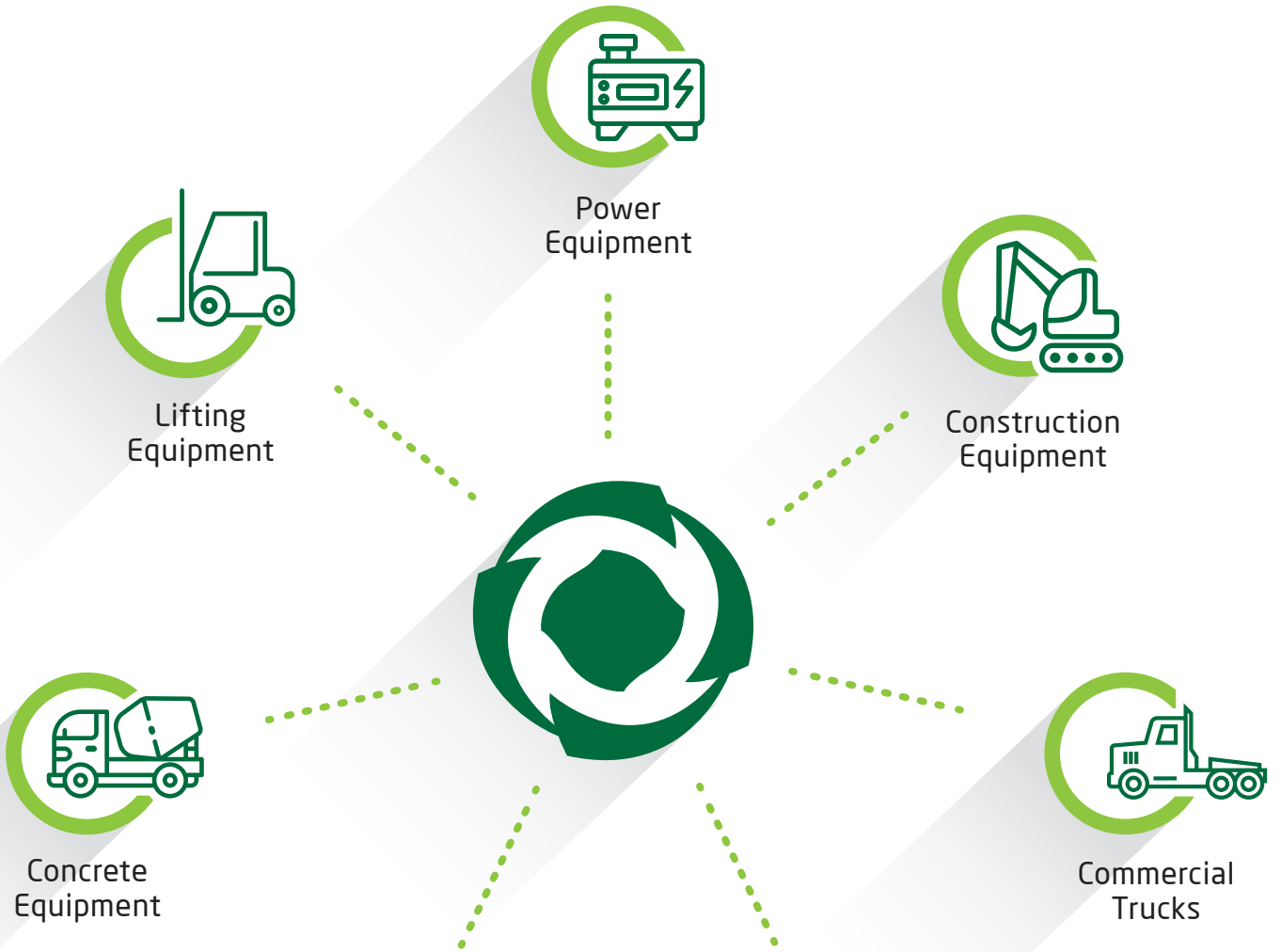

PEAX
Equipment Rental



Parts and
After Sales



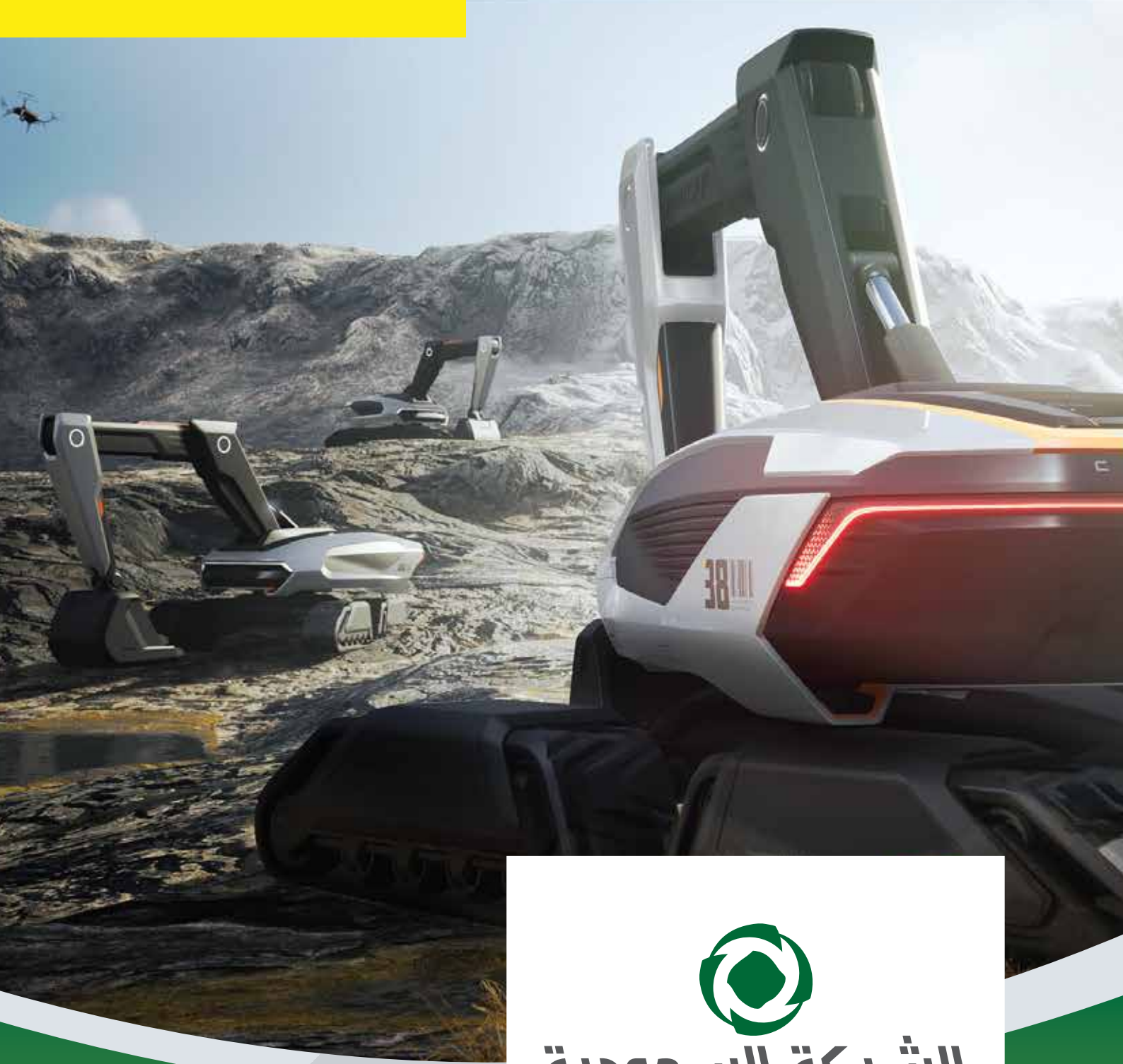

الشركة السعودية
لمعدات الديزل المحدودة
SAUDI DIESEL EQUIPMENT

**OUR
VISION**

**“To Be Your Preferred
Equipment Provider”**



Our Mission

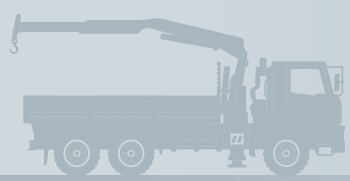



Drive success through competent, well-trained and motivated employees working in an ethical healthy environment

Provide efficient, reliable and cost-effective equipment solutions to the market.



Support **Saudi's Vision 2030** through effective recruitment, and development programs.

Ensure highest level of customer's satisfaction via continuous organizational enhancements



Increase market share by strengthening our presence and expanding into new areas, based on solid business strategic planning.



POWER EQUIPMENT

SAUDI DIESEL EQUIPMENT COMPANY IS THE REGION'S POWER SPECIALISTS.

Founded in **1978** with the core business of selling and manufacturing diesel generator sets for the local market, **SDEC** has since branded itself as the sole provider of fully customized power solutions (known as **SD Equipment**) within the regional market.



Ready-made or Manufactured Power Generators:

- ▶ Prime \ Standby Units
- ▶ Open Type \ Closed Type
- ▶ Sound Attenuated Solutions
- ▶ Mobile Solutions

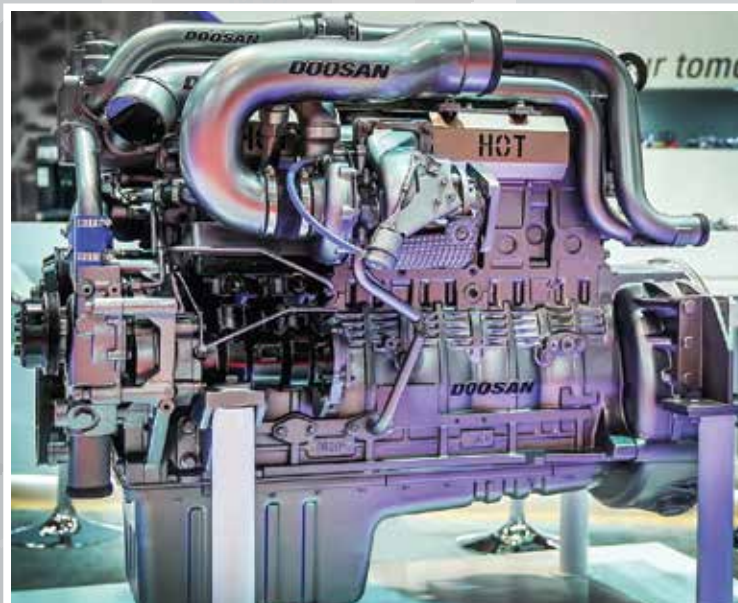

SD Equipment Manufactured Power Accessories

- ▶ ATS: Automatic Transfer Switches
- ▶ MTS: Manual Transfer Switches
- ▶ Control Panel with Sync Options
- ▶ Fuel Storage Systems

Diesel Engines

- ▶ Industrial, Marine, & Pump Applications



POWER EQUIPMENT

Switchgear and Control Panels

SD Equipment Switchgear offers electrical distribution and control solutions in the medium and low voltage range to industries and utilities.

Our product is Design, supply, delivery, installation, testing and commission of custom-built Low and Medium Voltage Electrical panel boards.





SD Equipment Provides the below Switchgear and Control Panels:

- ▶ Low Voltage Switch Gear
- ▶ Main Distribution Panel
- ▶ Sub-Main Distribution Panel
- ▶ Final Distribution Panel
- ▶ Automatic Transfer Switch
- ▶ Synchronising Panel
- ▶ Motor Control Center
- ▶ Motor Control Center Withdrawable
- ▶ Power Factor Correction Panel
- ▶ SD Equipment Standard Capacitor
- ▶ MTS Panels
- ▶ Low Voltage Switchrack
- ▶ Package Substation
- ▶ Medium Voltage Systems
- ▶ SD Equipment Standard Enclosure

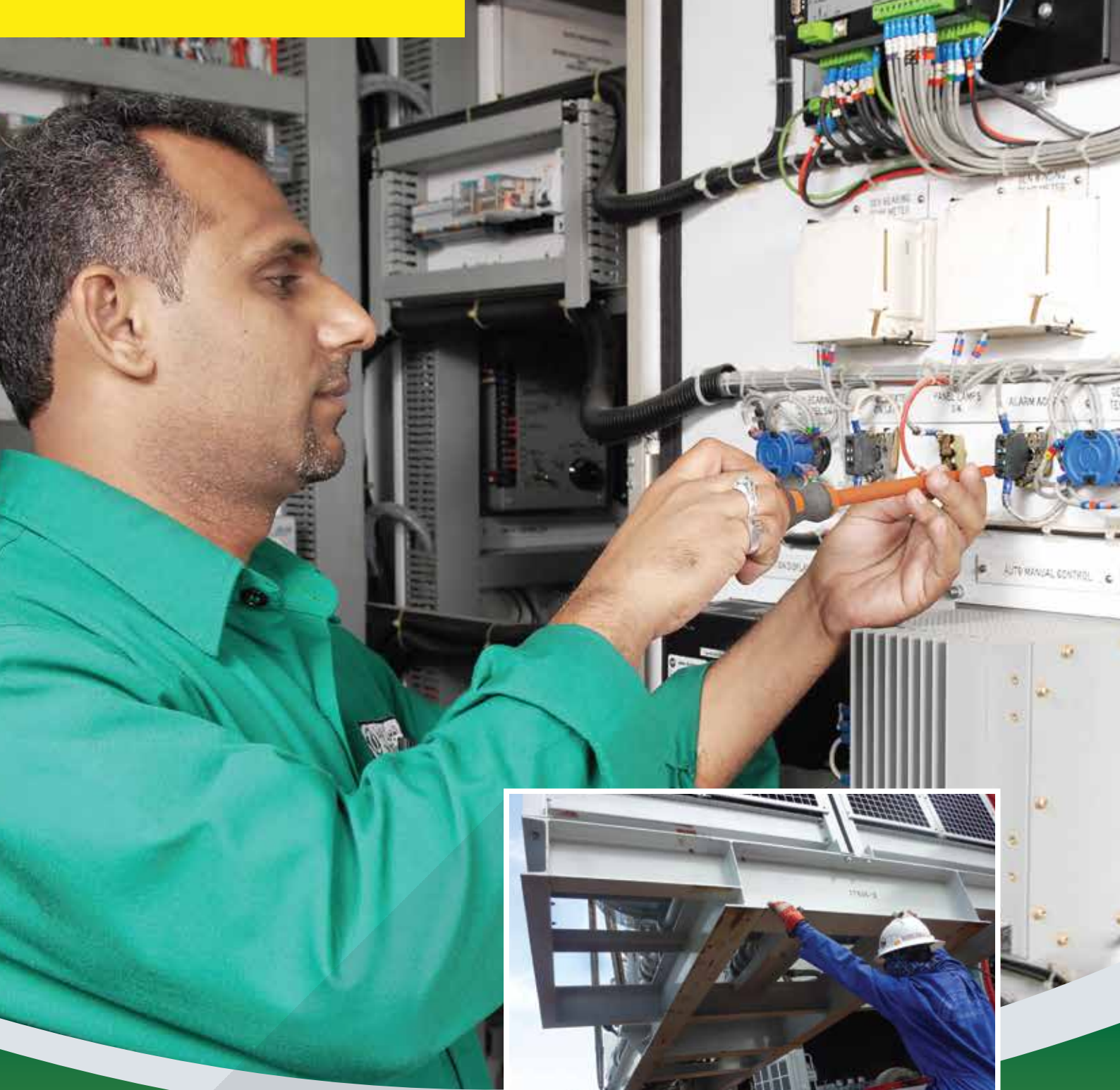

POWER EQUIPMENT Other **Services**

- ▶ Full Load Testing
- ▶ Simulation of Failures/Faults
- ▶ Power Projects Site Installation
- ▶ Project Commissioning
- ▶ Power House Design: Electrical & Mechanical
- ▶ Customized Project Solutions
- ▶ After Sales Logistical Services





Why SD Equipment?

► Using state-of-the-art quality major components representing:

- DOOSAN / Mitsubishi Gensets
- Allison Transmissions
- Donaldson Filters
- Marathon Electric
- Marelli Motori
- Nadic Leroy-Somer



In-house Engineering Support



Flexible Product Customization



Remote Monitor / Control



Sound Attenuated Solutions





CONSTRUCTION EQUIPMENT

**"Your Preferred Construction
Equipment Provider"**



SDEC IS THE WORLD'S LARGEST DISTRIBUTOR OF DEVELON CONSTRUCTION EQUIPMENT

Our Profile further arches to include **Mahindra**.

DEVELON and **Mahindra** represent a wide array of well-known, high quality and reliable Construction Equipment such As:

- ▶ Wheel Loaders
- ▶ Excavators
- ▶ Articulated Dump Trucks (ADTs)
- ▶ Backhoe Loader
- ▶ Attachments



WE PROVIDE OUR
CUSTOMERS WITH
AN ARSENAL OF
EQUIPMENT THAT IS
COMPATIBLE,
COMPREHENSIVE,
EFFICIENT, AND
COST-EFFECTIVE



CONSTRUCTION EQUIPMENT

Wheel Loaders

At **SDEC** we bring you the best of **DEVELON** Wheel Loaders. Designed to scoop, carry and load materials with ease, these powerful machines face a wide range of material handling tasks.

Each model offers outstanding comfort features, superior lifting capacities, and enough torque to penetrate the hardest of materials. With its proven track record of durability & performance in the harshest of climates, **DEVELON** Wheel Loaders have proven to withstand this region's harshest demands and weather conditions.



DEVELON Wheel Loaders

(2 to 5.4 m³ bucket size)

- ▶ Various bucket sizes from 2 to 5.4 m³
- ▶ **DEVELON** Wheel Loaders are designed for convenience, safety, and durability
- ▶ Superior mechanical engine provides higher quality and lower maintenance costs than the complicated electrical engines
- ▶ Superior breakout force of up to 260 kN
- ▶ **DEVELON** parts are all designed in house, ensuring the best quality control and maximum performance
- ▶ Available at various operating weights 11.12 to 31.1 ton
- ▶ Fastest Wheel Loader in the KSA



DISD Wheel Loaders

(1.7 to 3 m³ bucket size)

- ▶ Various bucket sizes from 1.7 to 3 m³
- ▶ Specifically designed to withstand the region's harshest weather conditions
- ▶ Breakout force of up to 16.2 tons
- ▶ Operating weights from 10.5 to 17.3 tons
- ▶ A Pioneer of Low RPM Engine Matching Technology
- ▶ Highest quality and lower maintenance cost are ensured with the use of **DEVELON's** superior mechanical engine
- ▶ Greater reliability ensured by efficient cooling





CONSTRUCTION EQUIPMENT

DEVELON Excavator

Why DEVELON Excavators?

- ▶ **DEVELON's** products guarantee a level of proven quality that is unparalleled.
- ▶ A wide array of attachments to fit many applications.
- ▶ Designed for long life with its sturdy frame and reinforced upper structure.
- ▶ Equipped with world-class cabins that combine superior comfort, excellent visibility and low noise levels.
- ▶ Proven track record of reliability & efficiency in the KSA.
- ▶ Superior mechanical engine provides higher quality and lower maintenance costs than the complicated electrical engines.





Wheel Excavators

(5.55 to 20.8 tons)

Delivers outstanding performance and stability as well as enhanced fuel efficiency. **DEVELON** wheeled excavators are a popular choice for operators tackling utility work, street maintenance and construction site tasks.



Mini Excavators

(2.79 to 8.38 tons)

Offers powerful digging capability, great hoisting power, convenience for diverse work environments, and easily controlled. Optimum for inner city demands and narrow working conditions.



Crawler Excavators

(14 to 70.1 tons)

DEVELON's medium-large excavator boasts a robust body for stable work, and superior power for ultimate performance, regardless of the task. Once equipped with a hydraulic breaker, the excavator becomes ideal for heavy breaking at quarries and other demanding sites.

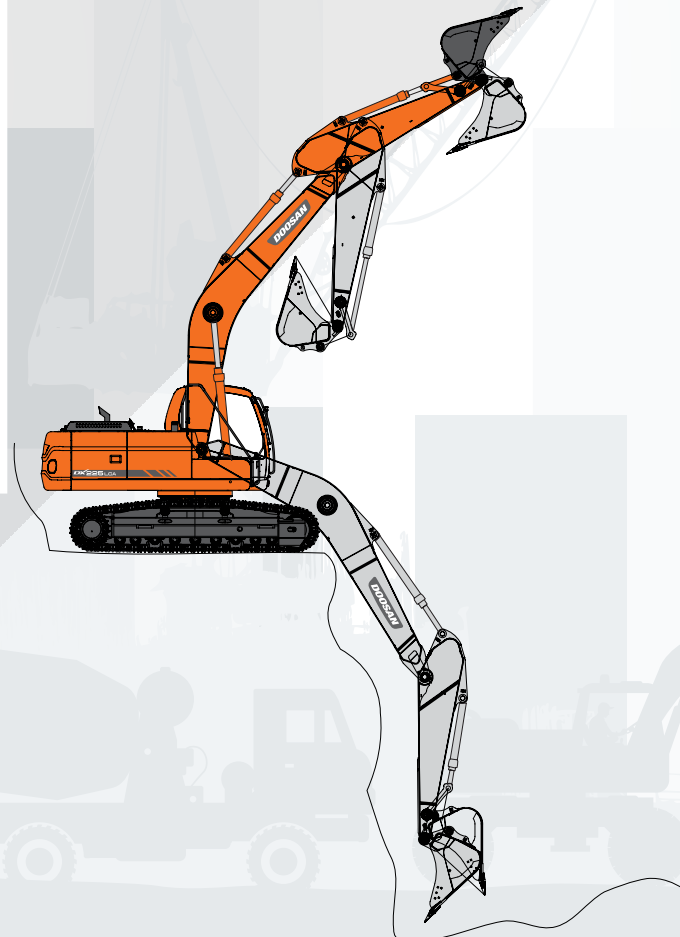

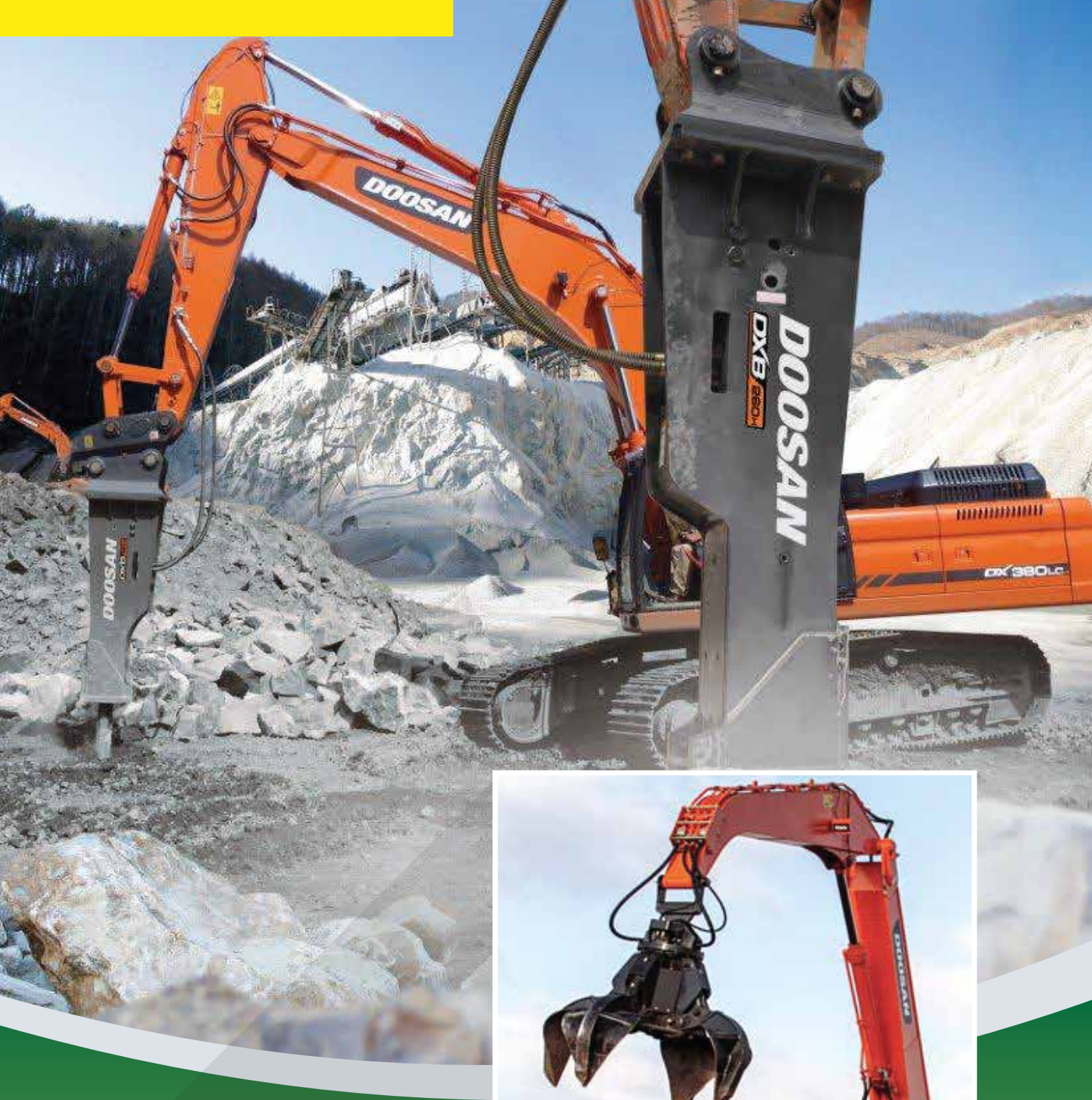

CONSTRUCTION EQUIPMENT **DEVELON ATTACHMENTS**

SDEC specializes in providing reliable solutions for its clients, which includes helping them getting the most out of their equipment and pushing their fleets to the next level.

In doing so, **SDEC** believes that a unique and reputable line-up of Attachments is an essential tool for such an endeavour. As such, **SDEC** has aligned itself with **DEVELON**, the best and the most trustworthy partner in the attachments market.



**WE HAVE AN
ATTACHMENT FOR
EVERY APPLICATION**

DEVELON Attachments

- ▶ Hydraulic Breakers
- ▶ Pallet Forks
- ▶ Quick Couplers
- ▶ Talon Buckets
- ▶ Vibro Rippers
- ▶ Sky Hooks
- ▶ Demolition Machine
- ▶ Front Shovel
- ▶ Material Handler
- ▶ and many more

**WE OFFER
PRE-ORDERED
MACHINERY AND
ATTACHMENT
CUSTOMIZATIONS,
MAKING US A
ONE-STOP-SHOP FOR
ALL YOUR MACHINERY
AND SPECIFIC
ATTACHMENT NEEDS.**





CONSTRUCTION EQUIPMENT

DEVELON Articulated Dump Trucks

“High Productivity Means More Material Moved Everyday”



DEVELON's Articulated Dump Truck (ADT) line-up offers larger load capacities in their respective weight class categories along with superior power and traction.

- ▶ Up to 490 HP @ 1,900 RPM
- ▶ Speed up to 55 km/h
- ▶ Up to 20 m³ Body Volume

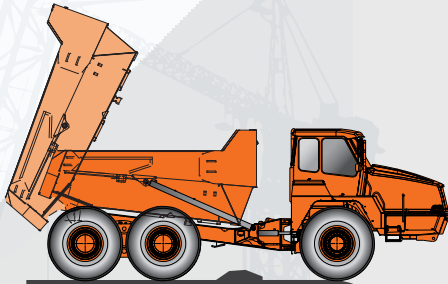

POWER

Exceed conventional concept of productivity, highest level of efficiency guarantees highest economic efficiency. **DEVELON** ADTs has the lowest operating & maintenance cost & highest power.

DEVELON ADTs automatic lubrication system, increased radiator and body capacity guarantee a long service life, & convenient operation.



DURABILITY



STABILITY

Designed for stable operation in any working environment. With various devices improved to give safe contact to the ground support.



COMFORT

Designed with top priority on operator's comfort. Excellent operability enables motion executed immediately.



EACH MODEL IS RELIABLE, DEPENDABLE & COST-EFFECTIVE



CONSTRUCTION EQUIPMENT

Mahindra EarthMaster Backhoe

**“Performance Par Excellence,
Most Versatile Backhoe Loader”**





Mahindra EarthMaster VX Backhoe Loader is a revolutionary new machine that was born after 4 years of research and over 20,000 hours of machine testing.

Every single product goes through stringent and thorough quality checks.

Why Mahindra EarthMaster Backhoe?

- ▶ Best-in-class fuel efficiency with proven **Mahindra** DITEC Engine
- ▶ Superior productivity and performance
- ▶ Low maintenance cost
- ▶ Superior convenience and comfortable design



Mahindra DITEC Engine

Mahindra has taken its learning from tractor engines, to bring its fuel efficiency down incredibly.

- ▶ 10% more saving with **Mahindra's** Engine
- ▶ 66.9 kW (91 HP) Turbocharged Intercooled Diesel Engine
- ▶ Fuel efficient, compact 4 cylinder 3532 cc engine
- ▶ BS-III Emission norms compliant

EarthMaster Joystick

Mahindra EarthMaster VX offers specially designed joysticks that are not just easy to use but also help minimise fatigue, thus allowing operators to work for longer hours.

- ▶ Joystick-operated effortless power controls
- ▶ Minimum skill required
- ▶ Enables less fatigue, longer working hours and enhanced productivity





COMMERCIAL TRUCKS

DAEWOO Trucks

DAEWOO Trucks provides unique experience to its customers by listening to their needs and reflecting them in its product development. **DAEWOO** strives to become the most respected Truck company in Korea.

Design Your DAEWOO: the regionally customized products will make us competitive in the rapidly changing circumstances.

And with **Design Your DAEWOO**, we will become the best commercial vehicle maker to achieve your goals.





DAEWOO Trucks

(10 to 40 tons hauling capacity)

DAEWOO manufacturers Medium to Heavy Trucks, ranging from **10 to 40 tons** on different wheelbases and axils, including:

- ▶ Medium Truck Chassis **4x2**
- ▶ Heavy Truck Chassis **6x4, 8x4, 10x4**
- ▶ Special Use Truck Chassis **4x4, 6x6, 8x4**
- ▶ Truck Heads **4x2, 6x2, 6x4, 6x6**

**SAUDI DIESEL
EQUIPMENT COMPANY
IS THE SOLE
DISTRIBUTOR FOR
DAEWOO TRUCKS,
KOREA**



Why **DAEWOO** Trucks?

- ▶ High-pressure fuel injection system that squeezes the maximum power out of each fuel drop
- ▶ Advanced tipper mechanism with new safety controls
- ▶ Outstanding driving and handling characteristics, with a powerful and rugged power train
- ▶ Comfortable and efficient ergonomically designed cabin
- ▶ Built to handle around-the-clock high speed operations
- ▶ **DAEWOO** Trucks leads the way in performance and features using its powerful, dependable engine.
- ▶ All wheel drive chassis offers strong power with great efficiency, suitable for advanced civil and military uses
- ▶ Abundant cargo hauling capacity, making **DAEWOO** Trucks a perfect solution for transporting large cargo loads





CONCRETE EQUIPMENT

Everdigm Concrete Pumps

SDEC provides an extensive line-up of **Everdigm's** Pumps.

These highly engineered products are the notion of productivity, durability and performance.

Based on FFH oil pressure system with its superior performance, these machines offer a paradigm shift in the concrete pumping industry.

Everdigm Pumps are a guaranteed partner for success.





Trailer and Truck-Mounted Pumps

(Up to 300 m Vertical Reach)

Features and Benefits:

- ▶ Reliable quality by application Rextroth
- ▶ Hydraulic pump unit Brand and stibel Gearbox
- ▶ Theoretical vertical concrete transfer up to 300 m, horizontal up to 630 m
- ▶ Theoretical concrete pressure up to 277 bar
- ▶ Hard metal of tungsten carbide wear plate and ring
- ▶ Wide space of platform load-able pipe

Boom Pump

(21 to 63 m Vertical Reach)

Features and Benefits:

- ▶ Maximize working efficiency with FFH System application
- ▶ Easy to control the boom speed by proportional system
- ▶ Manganic chrome of reducing pipe, wear-resistant material of delivery pipe
- ▶ Auto-lubricating device minimizing parts abrasion of repetitive working part
- ▶ Adjusting concrete pressure and delivery volume by each different pump cell option
- ▶ Stable and safe working by monitoring the boom movement



Placing Boom System

(Up to 42 m Working Radius)

Features and Benefits:

- ▶ Working radius up to 42 m or longer boom based on Project need
- ▶ Tubular mast and Tower mast type
- ▶ Maximum 37 kW output



CONCRETE EQUIPMENT
Batching Plants





Batching Plants

(30 to 180 m³ per hour)

SDEC has been a premier at providing complete concrete solutions, and as part of our constant endeavours to provide you with the best service available, we have brought to you the highest quality of batching plants the market has to offer.

Having been designed for maximum efficiency and reliability for producing all types of high quality concrete with production outputs starting from **30 to 180 m³** per hour, our batching plants are exactly what you need for your business to succeed.

AVAILABLE WITHIN A VARIETY OF OPTIONS AND CAN BE CONFIGURED TO MEET EACH CLIENT'S INDIVIDUAL NEEDS AND CAPACITIES





LIFTING EQUIPMENT

**“Your Preferred Lifting
Equipment Provider”**





DOOSAN Forklifts

(2 to 25 tons)

Saudi Diesel offers the best of **DOOSAN** Forklifts, bringing its clients a diverse choice of Diesel, LPG and Electric Models with various load capacities ranging from **2 tons up to 25 tons**.

DOOSAN is the world's leading value forklift brand built on a solid framework of manufacturing experience over **40 years**. **DOOSAN** are expanding their product range and continue to build on a reputation for reliable and high quality products designed to meet the most demanding needs of the global market.

DOOSAN's design breakthrough takes AC technology a leap beyond conventional forklifts by introducing revolutionary AC power and efficiency to both drive and hydraulic motors taking the industry lead in electric truck design and performance.



Why **DOOSAN** Forklifts?

- ▶ Proven and durable components
- ▶ High powered and fuel efficient Diesel and LPG Engine for high performance with minimum vibration
- ▶ Integrated Instrument Panel
- ▶ Enhanced Maintenance and Service ability
- ▶ Reliable power shift transmission
- ▶ Electric Counterbalance Trucks available from **1.5 to 5 tons 4-Wheel 80 volt**





LIFTING EQUIPMENT

DONGYANG Cranes

**“Our Cranes Specifically Customized
For The Region And Its Needs”**





Brick Cranes

(Height up to 17 m)

SDEC offers **DONGYANG** Brick Cranes specifically customized for this region and its specific needs. **DONGYANG** Brick Cranes are equipped with lifting capacities of **up to 1.4 ton** at Max. Boom Extension and Max. Lifting Height of **17 m**.

Features and Benefits:

- ▶ Two valves on top seat & flowing sharing control valve
- ▶ One touch hose connection
- ▶ Cast Iron Column
- ▶ The largest extension boom

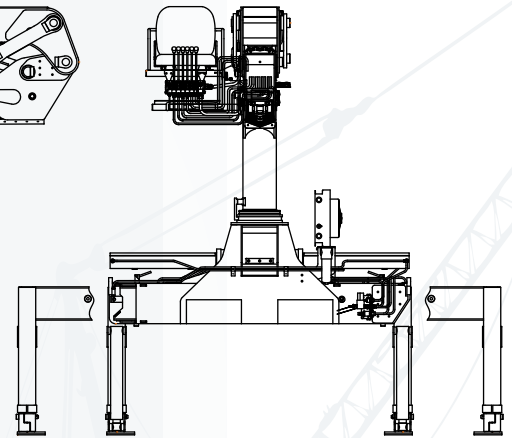
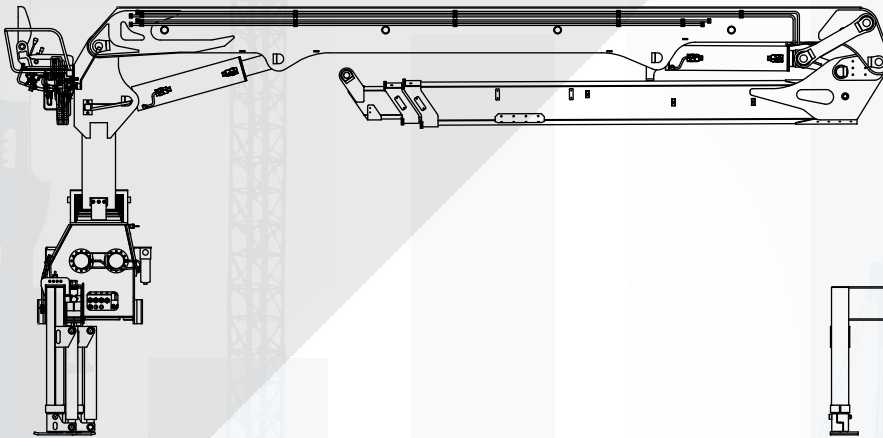

Stick Cranes

(Height up to 34.5 m)

We provide a wider selection of Stick Cranes that will surely satisfy all your lifting needs and more.

Features and Benefits:

- ▶ Operation height of **up to 34.5 m** with **30.5 m** radius
- ▶ Superior boom speed movement
- ▶ Boom Extension width of **up to 7.9**
- ▶ Wide selection from up to 12 models





AFTER-SALES SERVICES

Saudi Diesel Equipment operates a fully integrated transport service, which supplies parts to branches and dealers within hours of request.

Its parts inventory warehouses and speedy service support centers span geographically over the entire kingdom and an additional network of Sub-Dealers all over the Kingdom.

SDEC's policy is to offer efficient after sales backup, and strives to make dependable, genuine spare parts readily available to all customers.

SDEC replenishes its stock of spare parts continuously. Specific computer software tracks and manages stock in a proactive manner. It offers all **SDEC's** own parts products and genuine spares of Detroit Diesel, **DOOSAN**, **Allison**, **EVERDIGM**, **MSB**, **Mitsubishi**, and more.





24/7 SERVICE

Around the Clock Service

- ▶ Superior & effective after-sales services
- ▶ Unrivalled maintenance and support
- ▶ Team of experienced engineers & technicians
- ▶ Large engine overhaul facilities
- ▶ Full dynamometer testing
- ▶ Prompt & efficient service
- ▶ Kingdom-wide support, including clients site field service
- ▶ Customer operational and maintenance training programs





AFTER-SALES SERVICES

DEVELON Care Program

A package program of regular inspection and maintenance designed by **DEVELON** and carried out by **Saudi Diesel** includes:

- ▶ Performance test and adjustments
- ▶ Regular visits and machine analysis
- ▶ Wearable parts inspection
- ▶ Consumable items change by maintenance schedule
- ▶ Recommendation of service parts that need replacement
- ▶ Record & provide inspection results
- ▶ Certification for the machines by **DEVELON**



Why **DEVELON** Care?

Performance:

Optimized for **DEVELON** equipment to improve the equipment performance and reduce costs through fuel efficiency.

Quality:

The quality is beyond exceptional. They ensure that **DEVELON** equipment functions to the utmost through stable and constant operations.

Professionals:

Saudi Diesel provides only its top-class professionals, who are trained and certified by **DEVELON** to advise customers how to use parts correctly.

Service:

Parts and services are always closely related. It is the most efficient and economical to use genuine **DEVELON** parts with systemic support and certified service programs.



DEVELON Genuine Oil

- ▶ **DEVELON** Genuine Oil is the sole product certified by **DEVELON**. Caring your precious machine with **DEVELON** Genuine Oil which provides the best quality and reliability.
- ▶ Products Include **DEVELON** Genuine:
 - Engine Oil
 - Axle/Transmission Oil
 - Hydraulic Oil
 - Coolant and Grease





PEAX EQUIPMENT RENTAL

PEAX is one of the branches of the **Saudi Diesel Equipment Company** and is considered as the company's equipment rental arm. **PEAX** is a Leading Power and Equipment rental provider committed to quality in the Middle East region.

Its proven track record of satisfying the rental needs of its broad base of clients, including the most prestigious governmental organisations, oil & gas, contracting, commercial and large events firms, is a result of its philosophy of combining the latest innovative solutions with the highest talented expertise at the most competitive rates.

PEAX operates from its main locations in **Al-Khobar, Riyadh, Jeddah** and **Al-Madinah**. You can totally count on our 24/7 available Kingdom-wide Service & Maintenance Support for optimum site's up-time & operation continuity.

Rental Fleet

- ▶ Provisional Power Plants
- ▶ Large Power Generators
- ▶ Small Power Generators
- ▶ Light Towers
- ▶ Material Handling Equipment
- ▶ Air Conditioning Units
- ▶ Air Compressors
- ▶ Load Banks
- ▶ Fuel Tanks
- ▶ Transformers
- ▶ Other Power Accessories





TRAINING & DEVELOPMENT

Saudi Diesel believes that our strength comes from the expertise and knowledge of our employees gained throughout the years. Our training department strives to retain knowledge & further increase skills & competencies in line with our growth strategies.

Our main training facility in Al Khobar is equipped with all the tools necessary to train employees on theoretical subjects as well as hands-on mechanical & electrical applications related Diesel Engines, Heavy Machinery and Power Equipment. Our certified instructors can teach anything from basic Maintenance & Troubleshooting, basics of Mechanical & Electrical, all the way to advanced diagnosis and overhauling.





Customer Training:

In addition, our training department offers standard maintenance & operational courses to clients on-site or using our training facilities in the headquarters (Al Khobar). We also offer more sophisticated and customized courses based on our client's needs.

Vocational Training:

Saudi Diesel launched its first Vocational Training Program (VTP) in 2005, with the aim of attracting young Saudi talents who want to train and work within the professional industrial field.

The company held a joint agreement with the Human Resources Development Fund (HRDF) for the purposes of the completion of the vocational training, with an option of employment of trainees after their two-year program fulfilment.

Currently many of the VTP graduates are playing important roles in Saudi Diesel.



Coop Training:

SDEC believes in social responsibility. Our coop training programs runs throughout the year and hosts many students from local colleges & universities. We design training programs for each student to use their recently attained knowledge and put it into practice.



WE ARE GIVING YOUNG SAUDI NATIONALS THE OPPORTUNITY TO BECOME CONTRIBUTING MEMBERS OF SOCIETY, BY JOINING OUR WORKFORCE.



CUSTOMER TESTIMONIALS

Saudi Diesel Equipment Co. Ltd.



"Saudi Diesel staff are very professional and honest. They have a good service as whenever I need them they will be there in time".

Mohammed Alhattab - Owner
Alhattab Equipment Rental Company

"Honestly speaking I have previously dealt with other suppliers in KSA, but truly I found my peace of mind with **Saudi Diesel Equipment Co.** because of their excellent after sales service rendered."

Owayed Al Aswad - GM
Saudi Sevens Group for General Contracting

"We would like to extend our heartfelt thanks for the satisfactory services offered by you to our organization. We appreciate the way you conduct business with us. Your services were really exemplary, quick on time and your staff is also well mannered. You have managed the situations well in pressure conditions and clients have appreciated your leadership skills in managing the things in better way. We would like to admit that it is rare to find high standards of genuineness and reliability in the today's business world. It would be our pleasure to have the same services in the future and we sincerely wish all the very best for a successful future."

Tarik S. Breigish - Branch Manager
Matt Ladd - Country Manager
Hertz Equipment Rental Corporation

OUR PARTNERS

DEVELON



JAC MOTORS



mahindra
Construction Equipment



OUR CLIENTS



OUR LOCATIONS

