

**DEVELON**

---

**Operation and Maintenance Manual**  
**Hydraulic Breaker**  
**HB01 - HB32**

---

**Serial Number 1001 and Up**

HD Hyundai Infracore s.r.o. is an affiliate of HD Hyundai.  
DEVELON and the DEVELON logo are registered as trademarks  
of HD Hyundai Infracore Co., Ltd. in the United States and various  
other countries around the world.



August 2022

# Contents

<b>Specification.....</b>	<b>4</b>
External Dimensions .....	7
<b>To replace parts at regular intervals.....</b>	<b>11</b>
<b>Security Information.....</b>	<b>12</b>
Safety Clothing .....	12
Attention to obstacles .....	12
Notice for removal hydraulic breaker.....	13
Pay attention to falling broken objects.....	13
<b>Name of part and its function.....</b>	<b>14</b>
Structure.....	14
Hydraulic Piping Kit .....	16
<b>Correct Operation .....</b>	<b>17</b>
Safety Inspection before working.....	17
<b>Breaker Operation.....</b>	<b>21</b>
• Operation Method of Breaker.....	21
• Operation of Breaker.....	21
• Anti-Blank Firing.....	22
• Auto Grease.....	23
<b>Disassembly and Installation of Breaker.....</b>	<b>28</b>
Breaker's Disassembly .....	28

# Contents

<b>Disassembly and Installation of Breaker.....</b>	<b>30</b>
Breaker's Installation .....	30
Breaker Maintenance .....	30
<b>Tool .....</b>	<b>31</b>
Please use original DOOSAN tools only.....	31
Tool Dimension .....	31
Tool Type and Application.....	31
Replacement of Tool .....	32
Replacement of Tool .....	33
Replacement of Rod Pin .....	34
Replacement of Front Cover .....	35
Replacement of Ring Bush.....	36
Warranty of Tool.....	37
Warranty Assurance Standard Based on Fracture Face.....	38
<b>Gas Charging &amp; Adjustment.....</b>	<b>40</b>
Adjustment the pressure of nitrogen chamber.....	40
The method of checking the gas pressure.....	40
The method of charging the gas nitrogen.....	40
Set the pressure range of Relief valve.....	41
The adjustment of accumulator pressure.....	41
The method of checking the gas pressure.....	42

# Contents

<b>Maintenance .....</b>	<b>43</b>
All bolts and Nuts .....	43
Checking wether the rod pins are damaged.....	46
Chisel and Rod Pins.....	46
Chisel and Front Cover .....	46
Injecting Lubricating Grease.....	47
Hydraulic oil.....	47
Oil leakage .....	48
<b>Trouble-Shooting .....</b>	<b>49</b>

# Specification

## Form 1

Item	Model	HB02 (S/T/H)	HB03 (S/T/H)	HB04 (S/T/H)	HB06 (S/T/H)	HB08 (S/T/H)	HB15 (S/T/H)
Body Weight	kg	71	71	89	156	215	479
Total weight ( Side/Top/ Housing )	kg	95/95/129	95/95/129	158/158/180	263/343/361	335/410/451	761/866/1007
Length Side/Top/ Housing )	mm	1071	1090	1178	1373	1630	1994
		1235	1235	1344	1684	1738	2387
		1331	1331	1417	1660	1717	2354
Width Side/Top/ Housing )	mm	255	265	285	385	385	443
		226	226	285	385	390	458
		260	260	350	385	385	458
Height Side/Top/ Housing )	mm	413	435	500	696	760	966
		200	200	370	486	486	570
		295	295	305	486	486	570
Operating pressure	kg/cm <sup>2</sup> psi bar	90-120	90-120	90-120	110-140	120-150	150-170
		1280-1700	1280-1700	1280-1700	1562-1988	1704-2130	2130-2414
		88-117	88-117	88-117	108-137	118-147	147-166
Hydraulic flow range	l/min	20-30	20-30	25-50	40-70	50-90	80-110
Impact frequency	bpm	700-1200	700-1200	600-1100	500-900	400-800	350-700
Diameter of hose	mm	12.7	12.7	12.7	12.7	12.7	19.05
	nch	1/2	1/2	1/2	1/2	1/2	3/4
Diameter of Tool	mm	45	45	53	68	75/80	100
Weight of Tool	kg	8	8	9	18	26	57
Suitable Carrier	m <sup>3</sup>	0.03-0.1	0.03-0.1	0.06-0.2	0.15-0.3	0.2-0.35	0.4-0.6
Suitable Carrier	ton	1.2-3.0	1.2-3.0	2.5-4.5	4-7	6-9	10-15
Valve Type		Inward	Inward	Inward	Inward	Inward	Inward
Accumulator exists		No	No	No	No	No	No

# Specification

## Form 2

Item	Model	HB20 (S/T/H/FH)	HB22 (S/T/H/FH)	HB30 (S/T/H/FH)	HB32 (S/T/H/FH)
Body Weight	kg	850	956	1092	1313
Total weight ( Side/Top/ Housing )	kg	1653/1847 /1751/1751	1809/2094 /1935/1935	2218/2380 /2457/2457	2577/2745 /2968/2968
Length Side/Top/ Housing )	mm	2423	2480	2640	2776
		2900	2866	2897	3102
		2688	2793	3002	3105
Width Side/Top/ Housing )	mm	575	575	665	665
		575	575	665	665
		575	575	665	665
Height Side/Top/ Housing )	mm	1202	1335	1343	1382
		710	710	760	760
		710	710	760	800
Operating pressure	kg/cm <sup>2</sup> psi bar	160-180	160-180	160-180	160-180
		2272-2556	2272-2556	2272-2556	2272-2556
		157-177	157-177	157-177	157-177
Hydraulic flow range	l/min	130-150	120-180	150-190	180-240
Impact frequency	bpm	400-600	350-500	350-600	300-450
Diameter of hose	mm	25.4	25.4	25.4	31.75
	nch	1	1	1	1 1/4"
Diameter of Tool	mm	135	140	150	155
Weight of Tool	kg	115	135	157	190
Suitable Carrier	m <sup>3</sup>	0.6-0.8	0.7-0.9	0.9-1.2	1.1-1.4
Suitable Carrier	ton	18-26	18-26	27-35	28-35
Valve Type		outward	Inward	outward	Inward
Accumulator exists		Yes	Yes	Yes	Yes

# Specification for EU

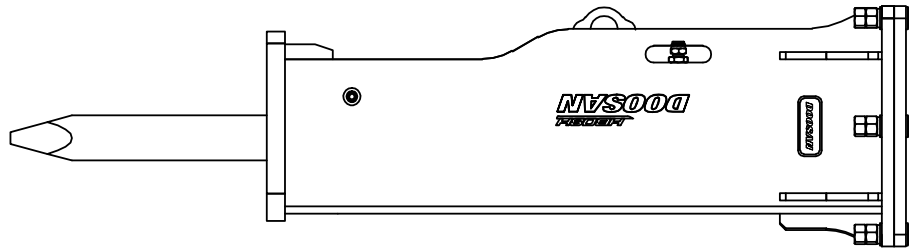

## Form 3

Item	Model	HB01	HB03	HB04	HB06	HB08	HB15/FH	HB22/FH	HB32/FH
Body Weight	kg	53	71	89	156	215	479	956	1313
Total weight	kg	95	100	150	300	390	900	1780	2660
Length	mm	1009	1107	1210	1390	1491	2065	2472	2762
Width	mm	260	260	260	328	328	440	560	640
Height	mm	298	298	298	400	400	520	710	766
Operating pressure	kg/cm <sup>2</sup>	90-120	90-120	90-120	110-140	120-150	150-170	160-180	160-180
	psi	1280-1700	1280-1700	1280-1700	1562-1988	1704-2130	2130-2414	2272-2556	2272-2556
	bar	88-117	88-117	88-117	108-137	118-147	147-166	157-177	157-177
Hydraulic flow range	l/min	15-25	20-30	25-50	40-70	50-90	80-110	120-180	180-240
Impact frequency	bpm	800-1400	700-1200	600-1100	500-900	400-800	350-700	350-500	300-450
Diameter of hose	mm	12.7	12.7	12.7	12.7	12.7	19.05	25.4	31.75
	nch	1/2	1/2	1/2	1/2	1/2	3/4	1	1-1/4
Diameter of Tool	mm	40	45	53	68	75/80	100	140	155
Weight of Tool	kg	4	8	9	18	26	57	135	190
Suitable Carrier	m <sup>3</sup>	0.07	0.03-0.1	0.06-0.2	0.15-0.3	0.2-0.35	0.4-0.6	0.7-0.9	1.1-1.4
Suitable Carrier	ton	0.8-2.5	1.2-3.0	2.5-4.5	4-7	6-9	10-15	18-26	28-35
Valve Type		Inward	Inward	Inward	Inward	Inward	Inward	Inward	Inward
Accumulator exists		No	No	No	No	No	No	Yes	Yes

# Specification

## External Dimensions 1

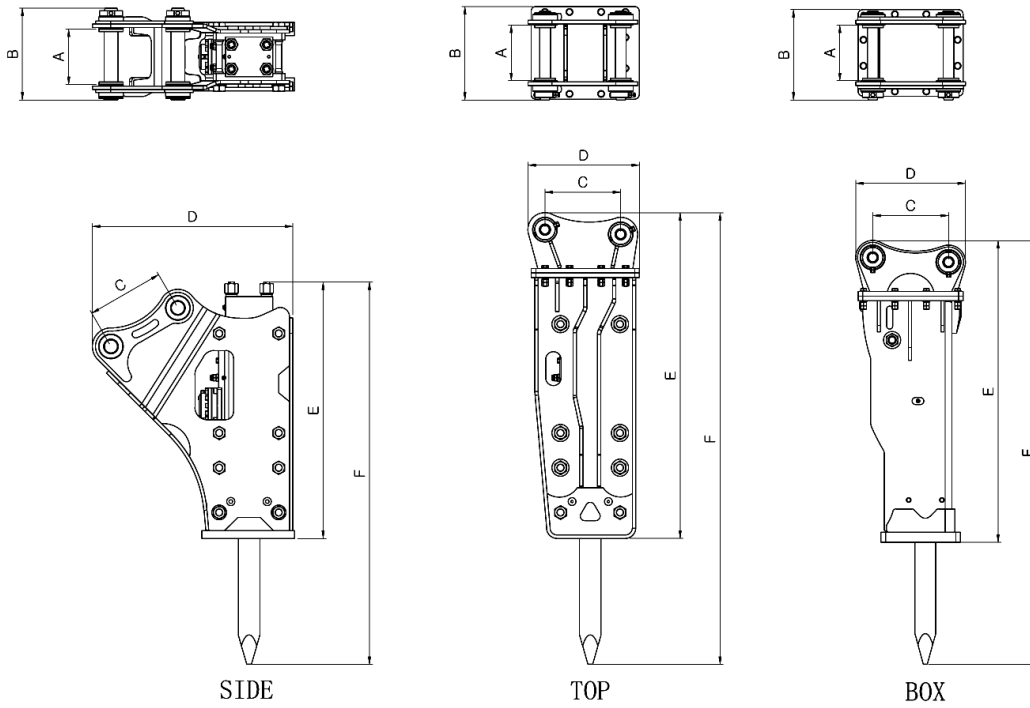

Form 4

Unit:mm

Model	Spec.	HB02	HB03	HB04	HB06	HB08	HB15	HB20
		(S/T/H)	(S/T/H)	(S/T/H)	(S/T/H)	(S/T/H)	(S/T/H)	(S/T/H/FH)
A	SIDE	145	145	165	210	210	275	360
	TOP	126	126	165	210	210	290	360
	Housing	141	141	141	210	210	290	360
B	SIDE	255	265	285	385	385	443	575
	TOP	226	226	285	385	390	458	575
	Housing	260	260	350	385	385	458	575
C	SIDE	126	165	240	285	340	390	465
	TOP	106	106	180	341	341	390	490
	Housing	185	185	185	341	341	390	465
D	SIDE	413	435	500	696	760	966	1202
	TOP	200	200	370	486	486	570	710
	Housing	295	295	305	486	486	570	710
E	SIDE	745	726	817	980	877	1090	1610
	TOP	891	891	1005	1080	1134	1560	2075
	Housing	994	994	1061	1241	1324	1747	2055
F	SIDE	1071	1090	1178	1373	1630	1900	2423
	TOP	1235	1235	1344	1684	1738	2387	1492
	Housing	1331	1331	1417	1660	1717	2354	2688



# Specification

## External Dimensions 2

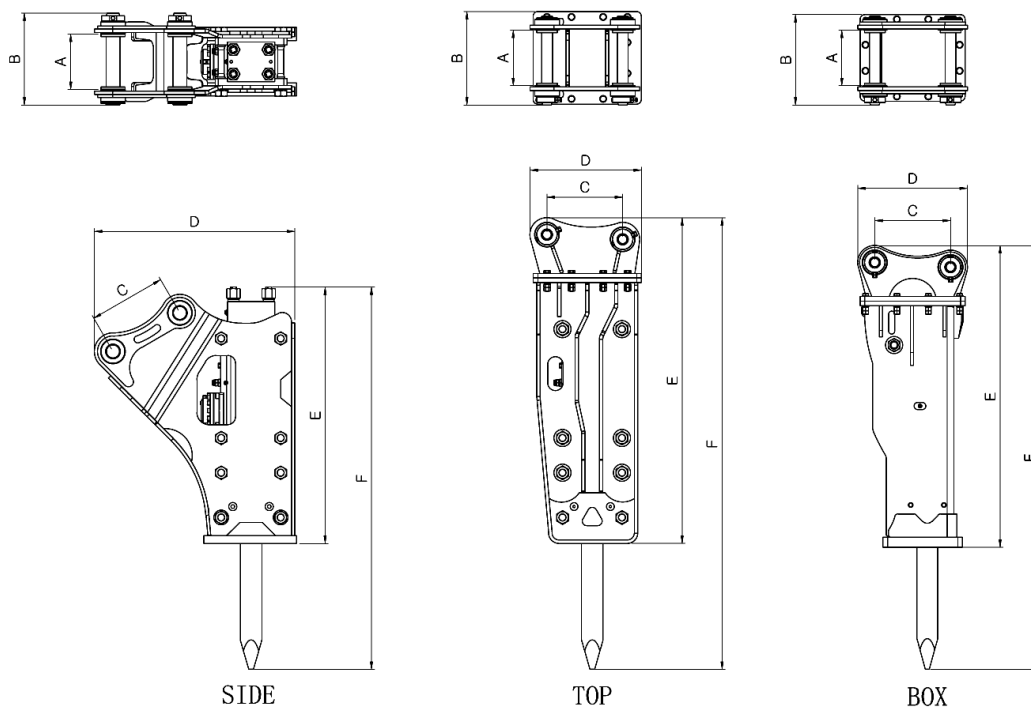

Form 5

Unit:mm

Model Spec.		HB22	HB30	HB32
		(S/T/H/FH)	(S/T/H/FH)	(S/T/H/FH)
A	SIDE	360	430	410
	TOP	360	430	410
	Housing	360	430	430
B	SIDE	575	665	665
	TOP	575	665	665
	Housing	575	665	665
C	SIDE	500	520	560
	TOP	490	520	560
	Housing	465	520	560
D	SIDE	1335	1343	1400
	TOP	710	760	790
	Housing	710	760	800
E	SIDE	1699	1682	1828
	TOP	2110	2234	2330
	Housing	2095	2203	2383
F	SIDE	2480	2640	2731
	TOP	2866	2897	3215
	Housing	2793	3002	3105

# Specification for EU

## External Dimensions 3

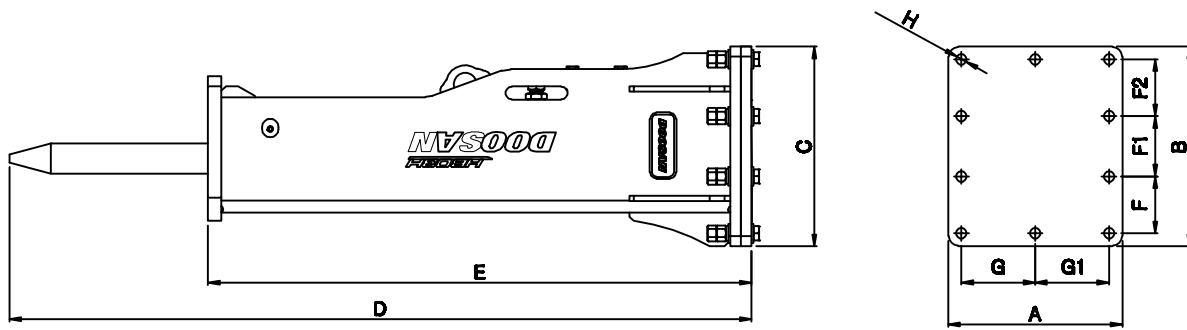

Form 6

Unit:mm

Model Spec.		Model		
		HB01	HB03	HB04
A	Housing	260	260	260
B	Housing	298	298	298
C	Housing	298	298	298
D	Housing	1009	1107	1210
E	Housing	742.9	811	880
F	Housing	85	85	85
F1	Housing	90	90	90
F2	Housing	85	85	85
G	Housing	110	110	110
G1	Housing	110	110	110
H	Housing	16	16	16

# Specification for EU

## External Dimensions 4

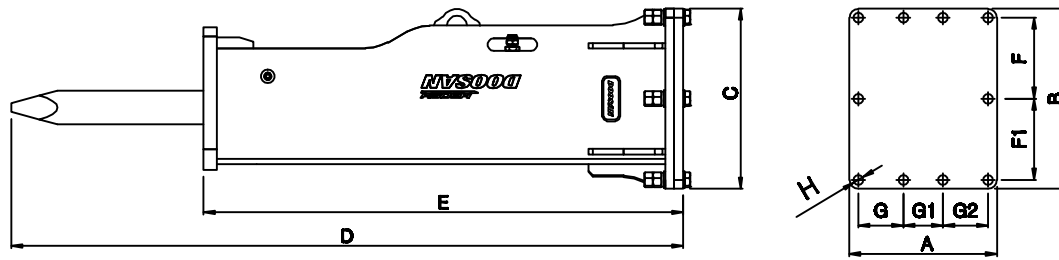

Form 7

Unit:mm

Model Spec.		HB06	HB08
		<b>A</b>	Housing
<b>B</b>	Housing	400	400
<b>C</b>	Housing	400	400
<b>D</b>	Housing	1390	1491
<b>E</b>	Housing	1013	1064
<b>F</b>	Housing	180	180
<b>F1</b>	Housing	180	180
<b>G</b>	Housing	100	100
<b>G1</b>	Housing	88	88
<b>G2</b>	Housing	100	100
<b>H</b>	Housing	22	22

# Specification for EU

## External Dimensions 5

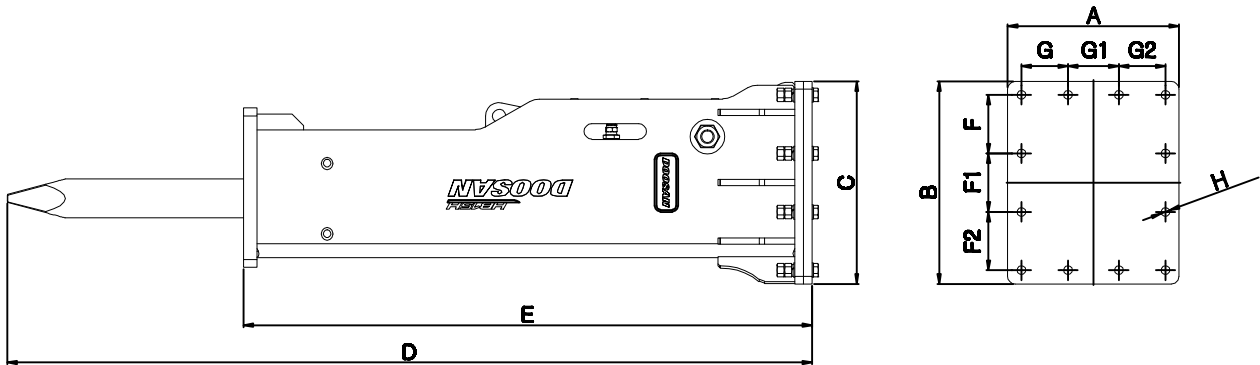

Form 8

Auto Grease only for HB15FH/  
HB22FH/HB32FH

Unit:mm

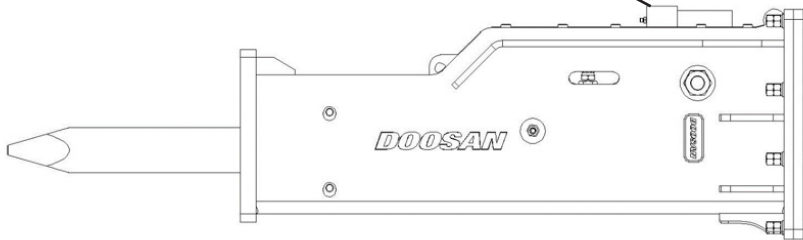

Model Spec.		HB15	HB22	HB32
		A	Housing	440
B	Housing	520	710	766
C	Housing	520	710	766
D	Housing	2065	2472	2762
E	Housing	1459	1750	1966
F	Housing	150	213	230
F1	Housing	150	214	236
F2	Housing	150	213	230
G	Housing	120	166	195
G1	Housing	130	168	180
G2	Housing	120	166	195
H	Housing	23	26	32

## To replace parts at regular intervals

1) The below wear parts must be replaced timely, in case they are worn or broken:

SERVICE INTERVAL	SERVICE ITEM
Every 2 hours	<ul style="list-style-type: none"> <li>• Grease front-head, tool, tool pins &amp; bushes.</li> <li>• Check hydraulic oil temperature, hose &amp; piping connections.</li> <li>• Tighten loose connections.</li> </ul>
Every 10 hours or daily	<ul style="list-style-type: none"> <li>• Check tool and tool pins condition. Grind off any burrs that may be present.</li> <li>• Check oil leakage.</li> <li>• Check gas pressure in the back-head. Refill the gas if necessary.</li> </ul>
Every 50 hours or weekly	<ul style="list-style-type: none"> <li>• Check gas pressure in the back-head. Refill the gas if necessary.</li> <li>• Check for wear of the tool, front bush, tool bush and piston lower part.</li> <li>• Check the hydraulic hoses. Replace if necessary.</li> <li>• Check through bolts, Replace and/or re-tighten if necessary.</li> </ul>
Every 200 hours or monthly	<ul style="list-style-type: none"> <li>• Check the clearance between tool and tool pins.</li> <li>• Check the clearance between tool and bushes.</li> </ul>
Every 500 hours or 3 monthly	<ul style="list-style-type: none"> <li>• Check oil leakage and replace seals if necessary.</li> </ul>
Every 1000 hours or 6 monthly	<ul style="list-style-type: none"> <li>• Change all seals and plugs including the accumulator diaphragm.</li> <li>• Change front bush.</li> <li>• Check inner bush and Replace if necessary.</li> <li>• Factory inspection by authorized service personnel recommended.</li> </ul>

- 2) Hydraulic oil, first replacement is at 250 hours; afterwards to replace every 500 hours. To replace oil filter at first 50 hours, afterwards to replace every 100 hours.
  - 3) To ensure normal use, customers shall purchase these wear parts together with hydraulic breakers for preparation in stock. Such as chisel, rod pin, stop pin, rubber plug, bolt, hydraulic hose, etc.
  - 4) Oil seal normally shall be replaced every 500 hours or 3 months.
  - 5) The above mentioned interval is subject to excavator's working time. Please use the genuine hydraulic oil of Doosan.
- ✘ The above mentioned wear parts are not covered under warranty.

# Security Information

Most of accidents happen due to overlooking security while operating, checking and repairing. It is very important to operate hydraulic breaker in correct way while working, because it can directly cause accident and machine breakdown due to wrong operation.

Please follow this manual's requirements to operate while hydraulic breaker working. We will not take responsibility for any accident or machine breakdown which is caused by incorrect operation or incorrect maintenance.

Please note these areas marked with  "Danger, Warning, Attention, Indication", which shall be paid much more attention during working.

\* If you have any inquiries on this manual, please contact the local distributor.

Our company can't foresee all the potential dangers during the whole process of hydraulic breaker's operation, inspection and reparation, so if you adopt different ways and methods during the process of operating the hydraulic breaker, you must ensure security and no mistakes, to avoid machine breakdown.

## Safety Clothing

Please put on safety cap, shoes, clothing and other safety devices ( glasses, gloves, earplugs, etc.) when operating or repairing the machine.

## Attention to obstacles

Attention to obstacles when working close to power line.

Must keep the shortest safety distance to power line.

To contact the power company in advance when you have to work close to power line.

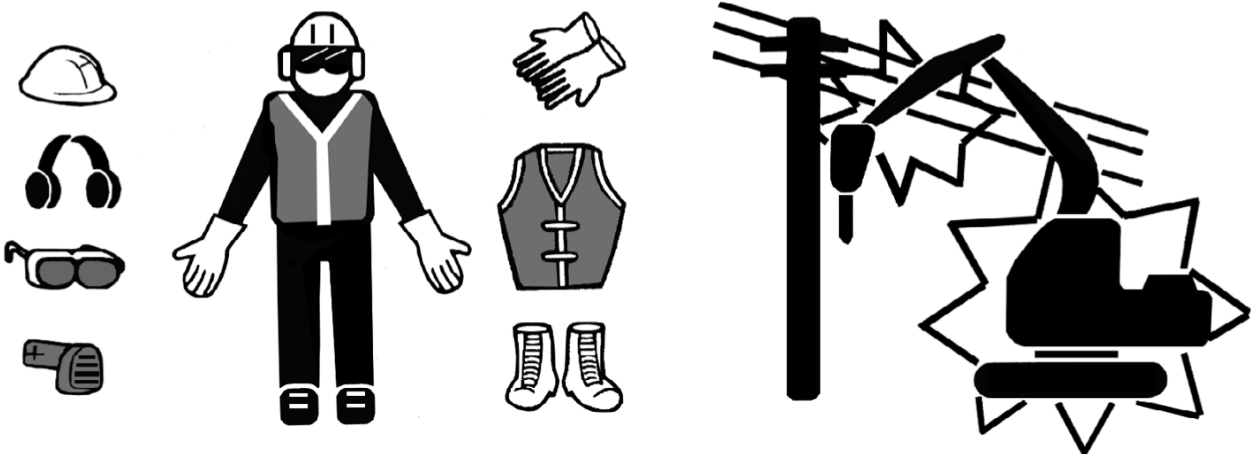

## Notice for removal hydraulic breaker

The hydraulic oil after operation is in high temperature and high pressure condition,If you disassemble nut,hose pipe,piping kit and other parts at this moment, it will cause the hydraulic oil to squirt out.So when you disassemble those parts,you must reduce the pressure and temperature of the hydraulic oil in the tank first.To contact the power company in advance when you have to work close to power line.



## Pay attention to falling broken objects

The staff should pay attention to the scattered dangerous objects after striking during the work, and select the suitable location according to the on-site operation.Prepare necessary protective measures.

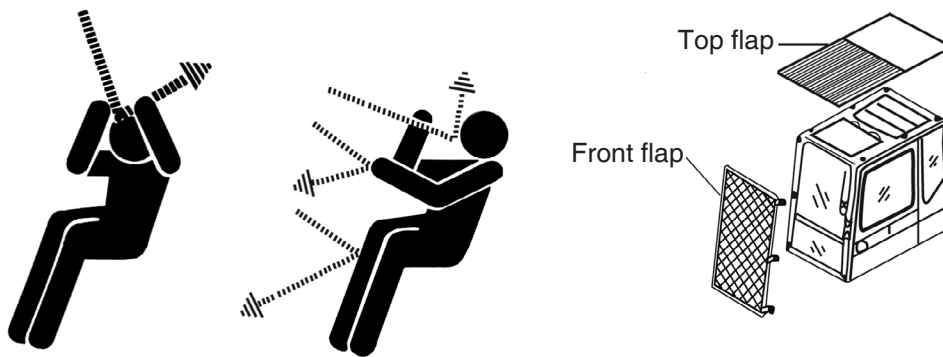

# Name of part and its function

## Structure

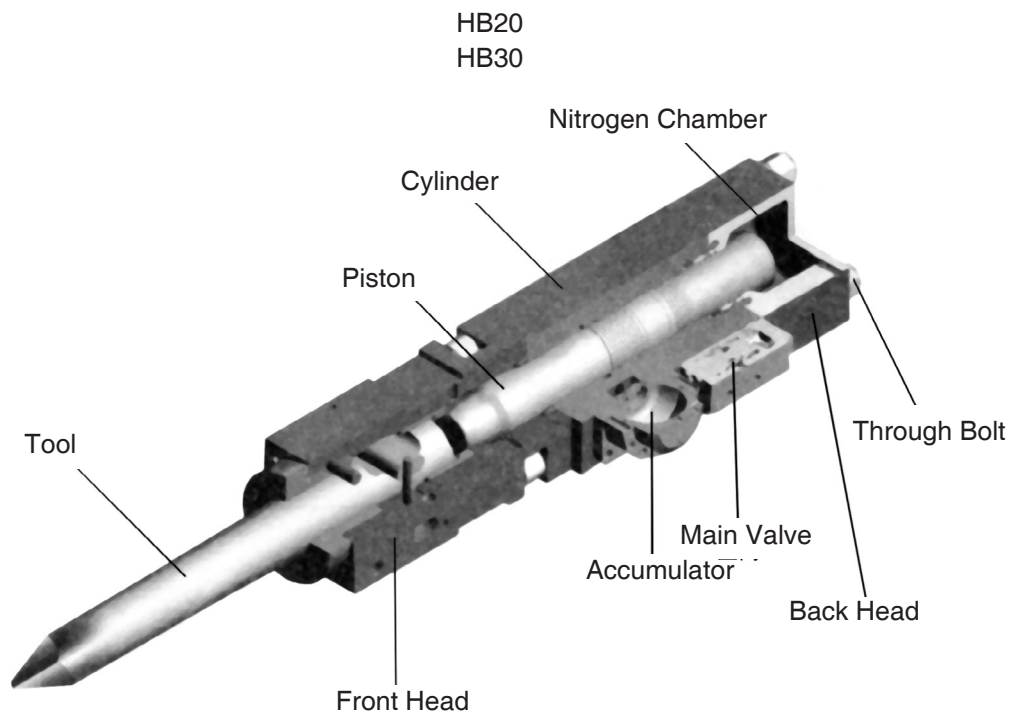
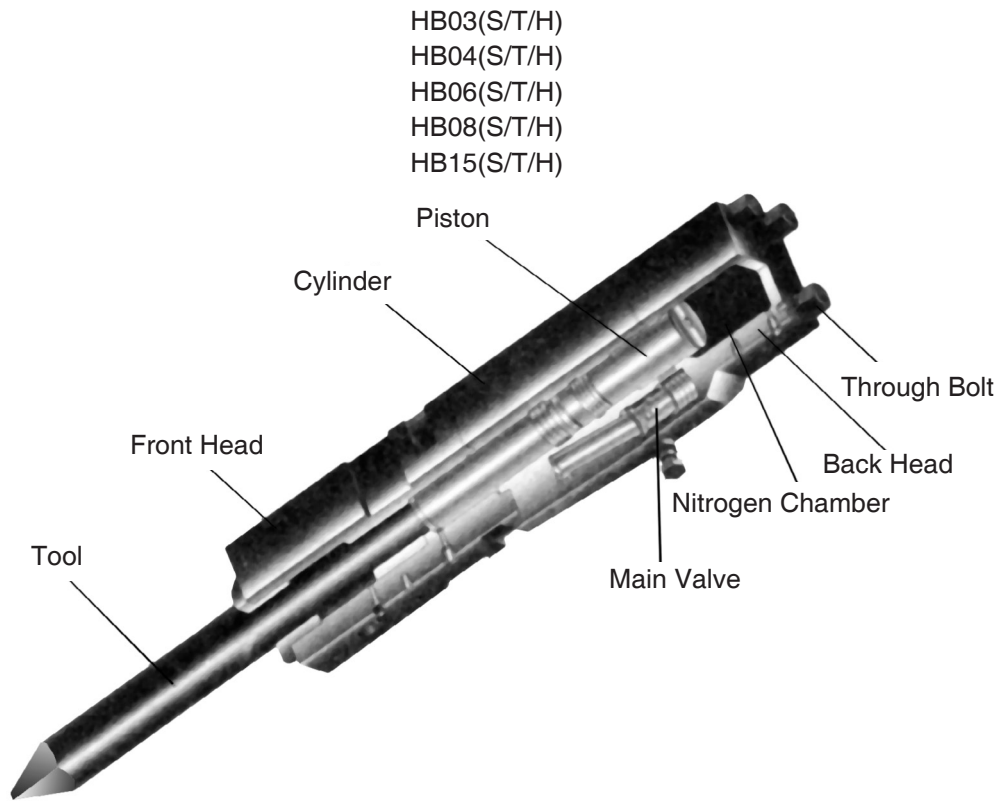



# Name of part and its function

## Structure

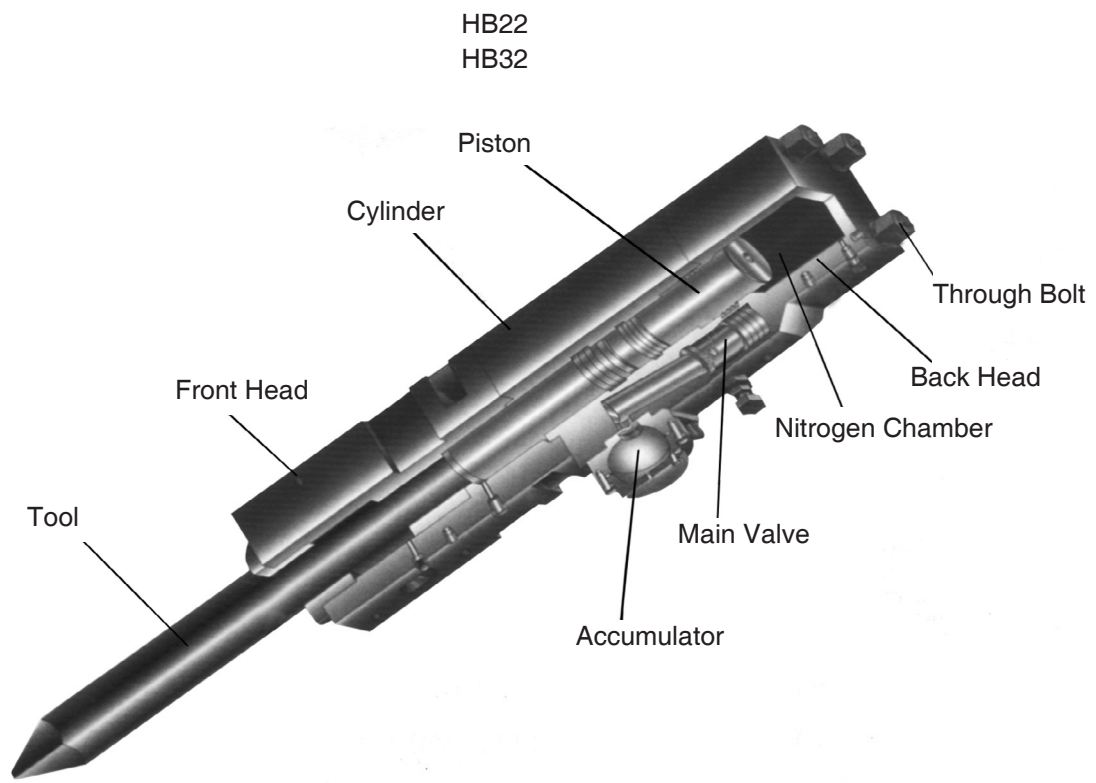

### Main Valve

The Main Valve controls reciprocates piston action with hydraulic oil distribution.

### Accumulator

Ensure the gas energy of the impact power.

Absorb the vibration pressure caused by the piston rebound.

Ensure the stability of hydraulic pressure.

### Nitrogen Chamber

Nitrogen charging Inject pressure

See Form 13 at Page 35

### Tool

There are five types of tool, such as moil type, blunt type and so on. See page 25 for more details. (Tool )

Please select according to the use.

# Name of part and its function

## Hydraulic Piping Kit

1. When you install hydraulic breaker on hydraulic excavator, be sure to use professional hydraulic pipe. Different excavators need to be equipped with different hydraulic pipelines.(Please contact local dealer.)

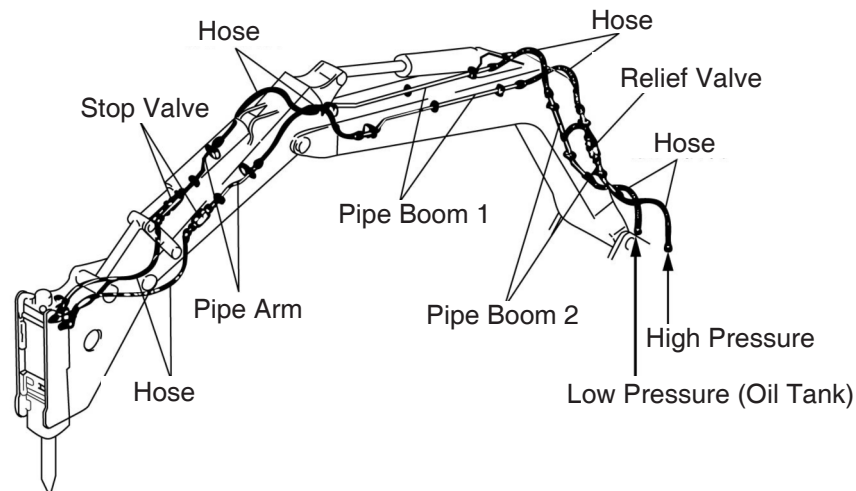

2. As the pump energy and control valve form of hydraulic excavator are different, the connection way of pipeline is completely different. There are two main methods:
  - 1) Prepare valve connection
  - 2) Connect pump directly

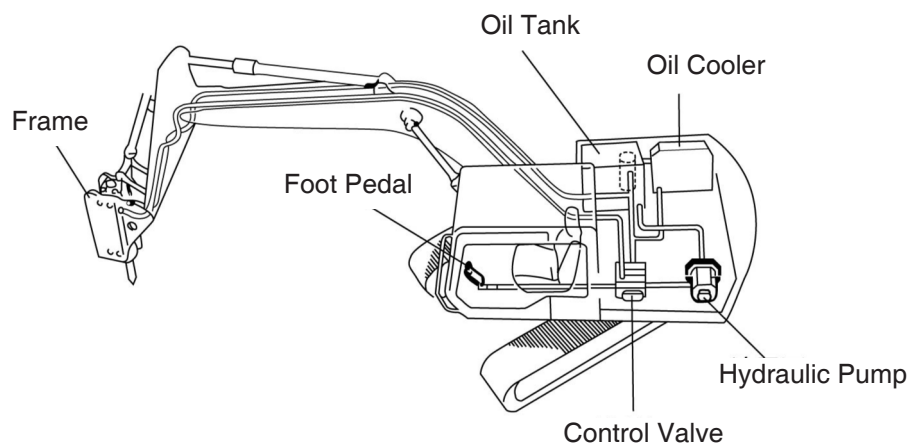

# Correct Operation

## Safety Inspection before working

- **Bolts and Nuts**

Please check whether all the bolts and nuts are tightened well. If any of them loosens, please tighten it immediately.

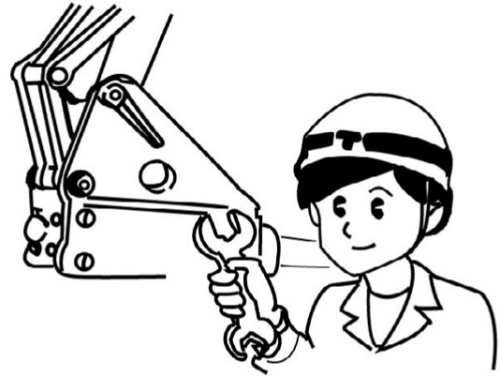

- **Hydraulic Oil**

Please check whether the hydraulic oil is enough. If it is very inferior, please change the oil immediately.

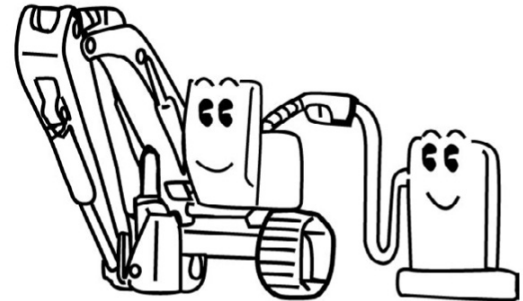

- **Warming up the machine**

Please do not leave the excavator during the warming up of the machine. It will be normal if the needle of the water thermometer is moving.

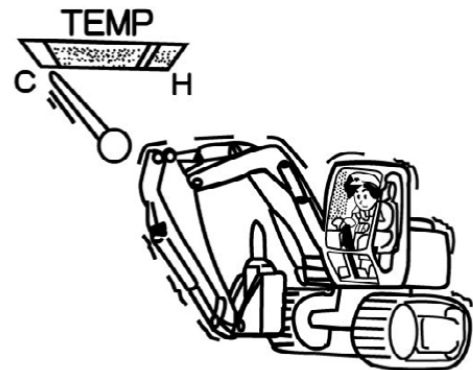

# Correct Operation

## Safety Inspection before working

- **Greasing**

Please inject the grease into the front head of the breaker.



- **Running-in operation**

Before the first time using the new hydraulic breaker, The Running-in operation should be done for an hour, Everyday before working this operation should be done for 10 minutes, during the running-in operation, the hydraulic oil is 70% of normal working flow; During this operation the impact of the breaker should be perpendicularly, slant impact is forbidden. Full-load working immediately after just starting the machine may cause the damage of the seal kits or other important parts.



# Correct Operation

## Safety Inspection before working

- **Blank Fire is forbidden**

The operation while the chisel has not got touch with the breaking object or they are not contacting tightly is called “Blank fire”. Blank fire will cause the damage of the parts, or the broken or loosen of the bolts and nuts.

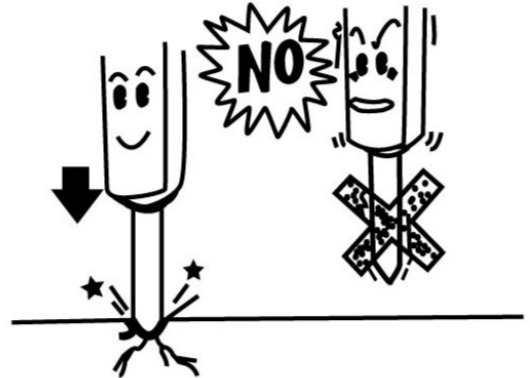

- **Continuous Impact is forbidden**

Please do not impact the same point of the breaking object continuously. It will cause the abnormal abrasion of the chisel or the damage of the other parts. Please move the chisel to the other impact point of the object if the current point can not be broken within 1 minute.



- **Shaking the chisel is forbidden**

Please do not shake the chisel, it will cause the damage of the through bolts, chisel and the seal retainer.

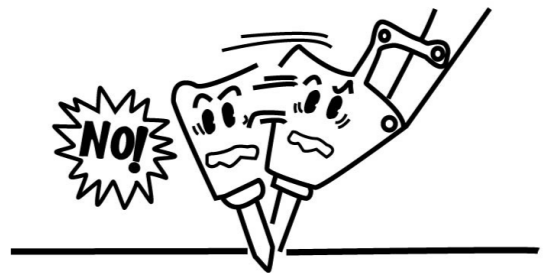

- **The sudden severe impact to the breaking object is forbidden**

Comparing with the bucket, hydraulic breaker is much heavier, so please operate the excavator slowly. Please do not contact the breaking object fiercely. Otherwise it may cause the damage of the front area of the excavator and the swing parts.



# Correct Operation

## Safety Inspection before working

- **Please do not operate hydraulic breaker with boom or arm cylinders fully extended**

Please do not operate hydraulic breaker with boom or arm cylinders fully extended, Please keep 100 mm cylinder stroke of base machine at least, otherwise, it may cause the damage of the cylinder and the front part area.

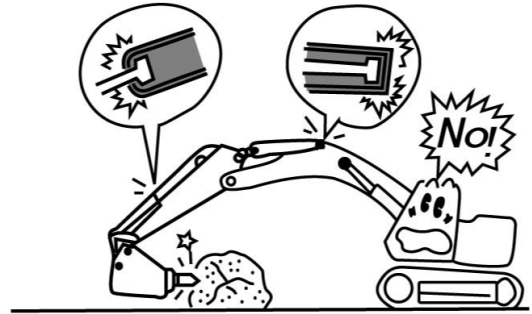

- **Operation under water is forbidden**

Please do not use the hydraulic breaker under the water, otherwise, it will damage it.

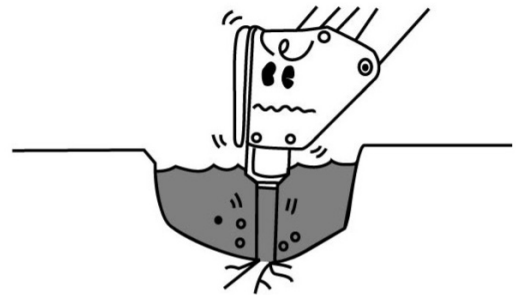

- **Hoisting is forbidden**

Please do not hoist weights by using the hydraulic breaker or its tool, it may damage the breaker and the arm of the excavator.

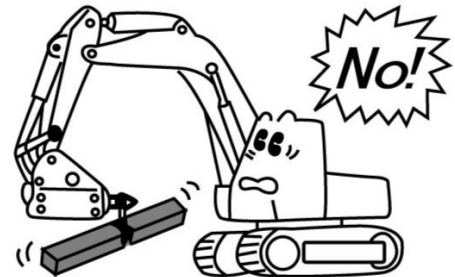

- **Operation during the hydraulic hoses vibrating excessively is forbidden**

If the hydraulic hoses are vibrating excessively, It indicates gas leaking from the accumulator or back head of the hydraulic breaker. In this case, please check the nitrogen gas pressure, and charge the gas with specified pressure.

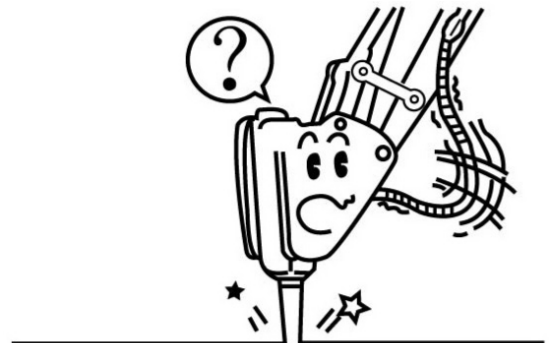

# Breaker Operation

## • Operation Method of Breaker

Pedal mode (pump direct connection mode, preparation valve mode): After thread on breaker's pedal, breaker start to work, after release the pedal, breaker will stop work.

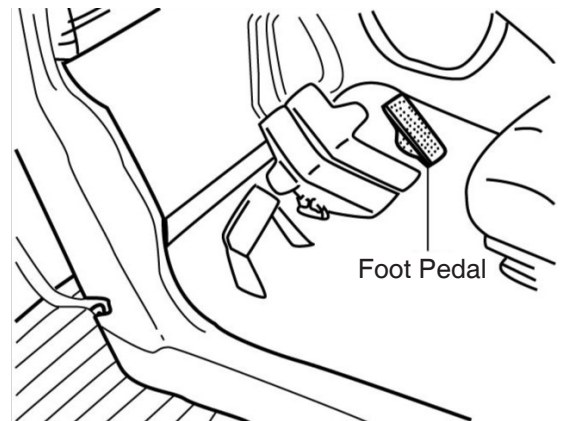

## • Operation of Breaker

Make chisel aim to the working object, then pressit.

Make chisel vertical placed, do break working by hand-operate or pedal-operate.

Once the working object is broken, stop work.

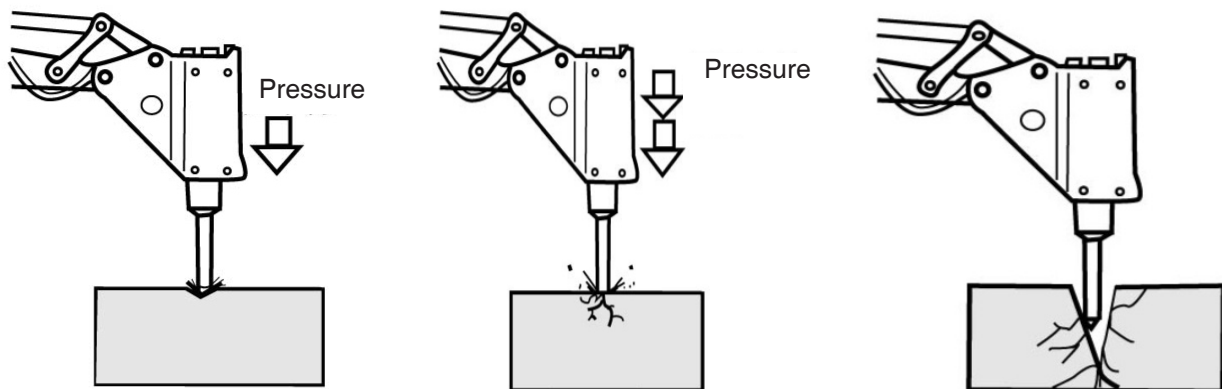

---

## WARNING

---

- First, do mechanical preheating, until the pointer of water thermometer start to move.
  - The revolving speed of engine must be below of setting value.
  - Don't continuous working in too hot condition in summer, otherwise the temperature of oil will be too high. If the temperature is over 80°, must stop work until the temperature come down.
-

# Breaker Operation

## Anti-Blank Firing

Auto Grease and Anti-Blank Firing is only for HB15FH/HB20FH/HB22FH/HB30FH/HB32FH. As shown below, the mode 1 is mode of Anti-Blank Firing. It's standard mode when it's delivered. The mode 2 is normal mode, Non Anti-Blank Firing. The mode 2 Assy is packaged in the Tool Box. The operator can replace it on site according to their requirement.

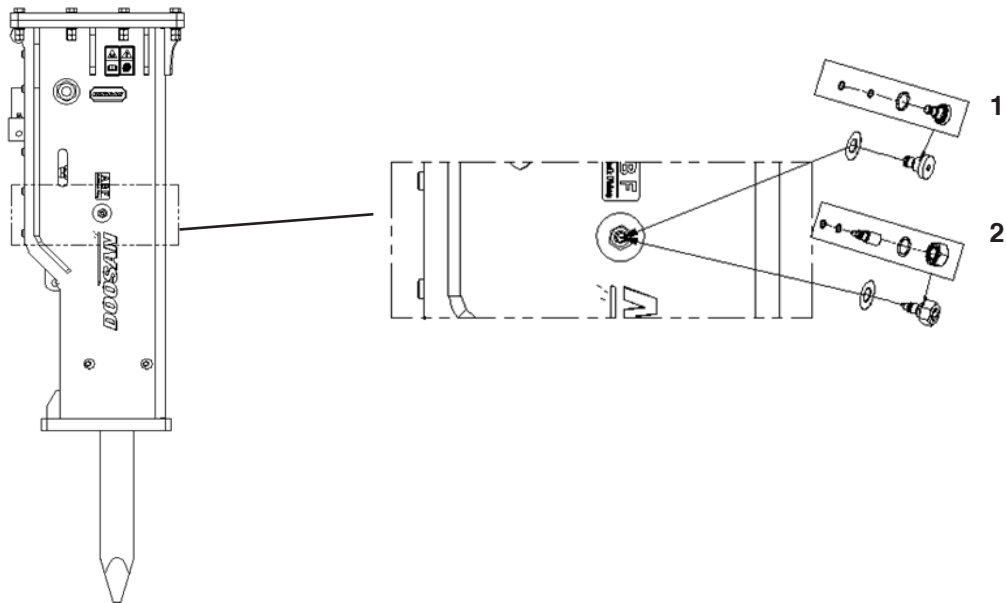

**Introduction of Anti-Blank Firing:** During the operation of hydraulic breaker, once the blank firing is occurred, the Anti-Blank Firing System will work. Even if the excavator does not stop working, hydraulic breaker will not impact unless the chisel contacts the rock again (Non blank firing). The impacting operation can be carried out again after the chisel is compacted normally.

**Principle of Anti-Blank Firing:** The piston and valve move back and forth through the internal oil circuit switching, so as to realize the impacting operation of hydraulic breaker. When there's blank firing, the internal high-pressure oil will relieve pressure through a specific oil circuit, so that the piston cannot be switched and realize the anti-blank firing function; After adjusting the position (Non blank firing), the chisel is compacted normally, and the pressure relief oil circuit inside hydraulic breaker is closed, so as to make the piston switch normally and realize the normal impact of hydraulic breaker.

**Benefits of Anti-Blank Firing:** It reduces the failure rate of hydraulic breaker and improve the efficiency in case of poor vision. If there is no Anti-Blank Firing system, once blank firing is occurred, it will cause serious damage to front head and its wear parts, and shorten the lifetime of hydraulic breaker. The Anti-Blank Firing system can effectively avoid it and protect hydraulic breaker.



# Breaker Operation

## Auto Grease

Auto Grease and Anti-Blank Firing is only for HB15FH/HB20FH/HB22FH/HB30FH/HB32FH.

Auto Greasing Device for Hydraulic breaker

AGP-HP400

Working Pressure	30~120bar	
Net Weight ( Without Greasing oil)	2.5 Kg	
Size	170mm x 80mm x 235mm	
Output Port Size	PF 1/4"	
Flow rate	0.1cc~0.7cc/min	
Recommend Grease	Material	MoS2
	Type	NLGL NO.2
	Diameter	Φ 62mm
	Length	200mm
	Weight	500g
Available temperature range	-15 C ~ 60 C	
Permissible Limit of main body temperature	-20 C ~ 90 C	

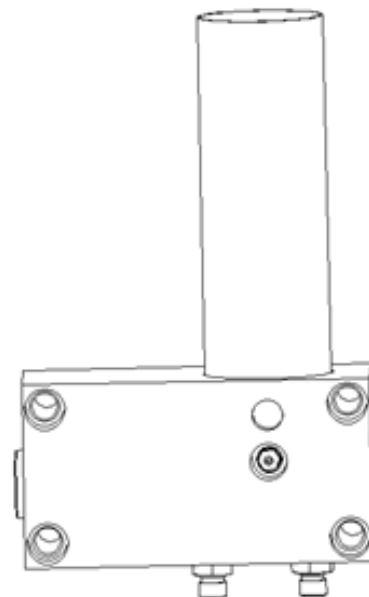

1. Push the Cartridge bottom until the greasing oil squeezed out about 10mm.

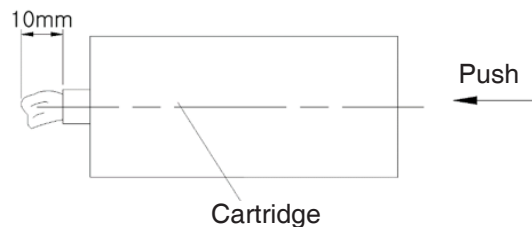

2. Before installation, it is necessary to fill the device with enough greasing oil.(higher than the thread),and completely eliminate the air in the device.

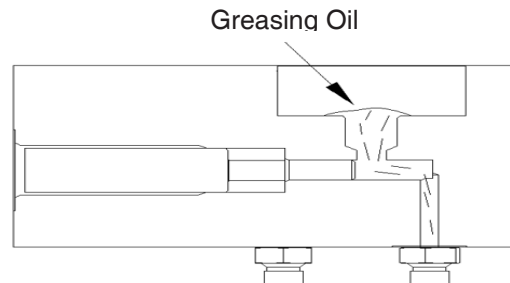

3. Insert the Cartridge & twist it until tightened.

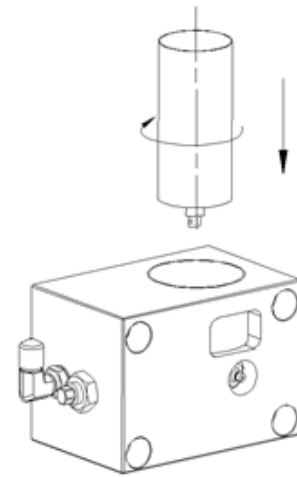

4. Notice

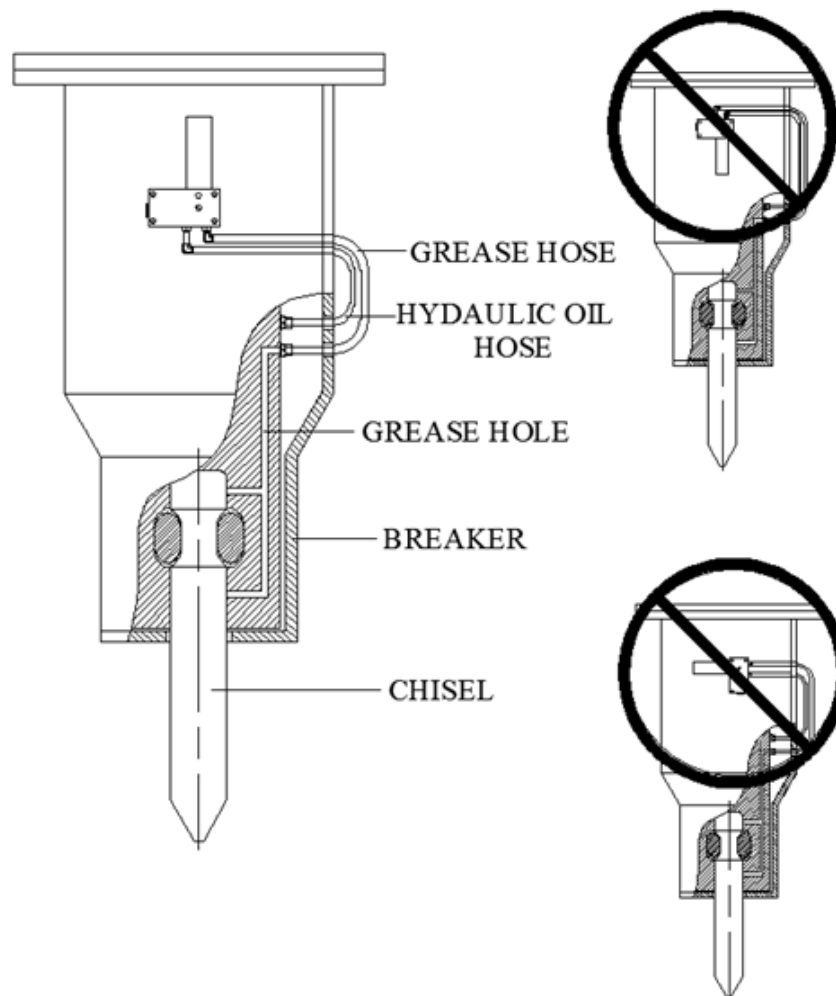

---

## IMPORTANT

---

- Correct installation of AGD system should set Cartridge direct up as shown in the diagram above.
-

---

## IMPORTANT

---

- The device should be tightened on the Breaker. Loosened bolt may cause serious damage or malfunction.
- 

---

## IMPORTANT

---

- The Grease Cartridge should be tightened on the Device Body. Loosened Screw may cause serious damage or malfunction.
- 

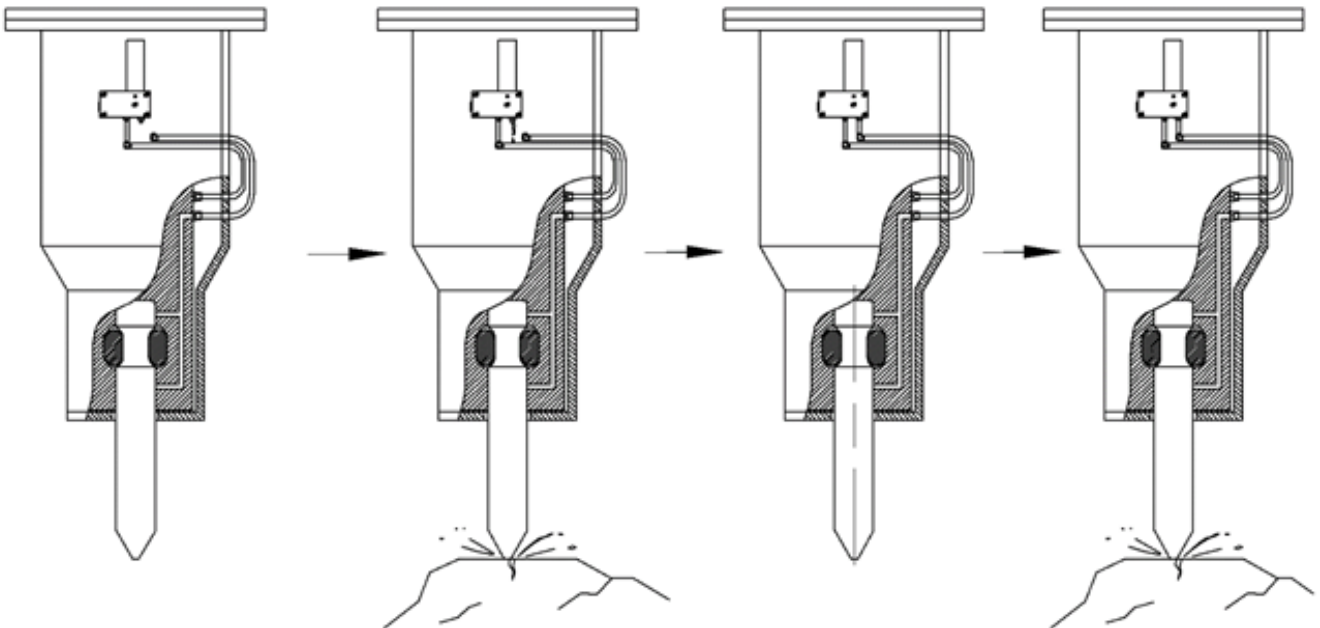

---

## NOTICE

---

- 1.Run the breaker without connecting the grease hose.
  - 2.Running the system over 3 mins. (If there is no oil out, repeat the installation step 1).
  - 3.Connect the hose.
-

---

## NOTICE

---

- Driver should pay attention during the work, prevent the AGD system to collide on the rock or other objects.
  - External or internal damages can cause malfunction.
- 

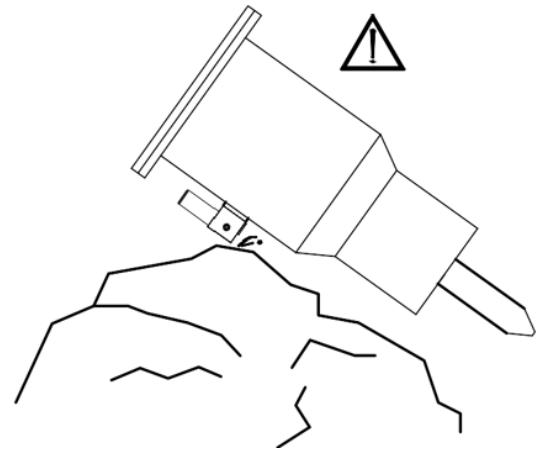

### 5. Grease refilling

Greasing oil is refilled by power Grease Device. It can be used without removing the grease Cartridge.

---

## NOTICE

---

- Please fill with lithium grease.
- 

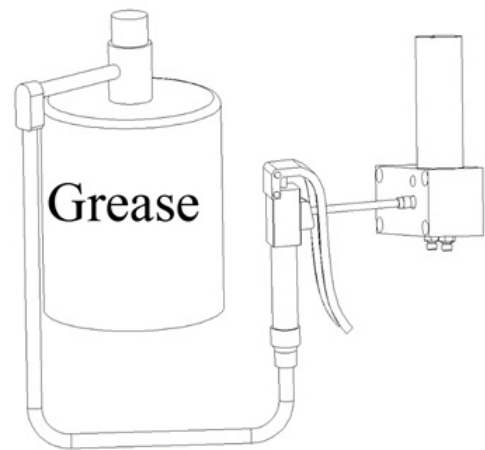

### 6. Greasing oil is refilled by Grease Gun. It can be used without removing the grease cylinder.

---

## NOTICE

---

- If the Breaker has not been used more than 2 months, please supply enough grease manually by Grease nipple before operation.
- 

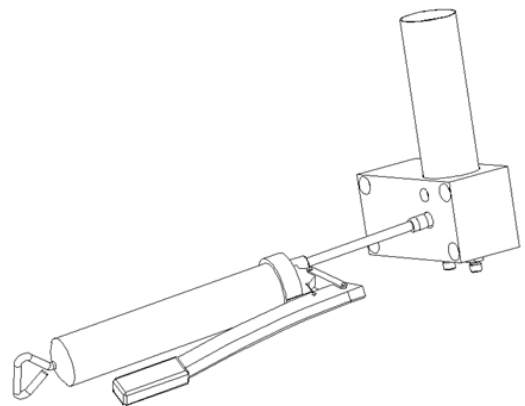

7. Adjustment of grease device

---

## NOTICE

---

- No spacers assembled will achieve maximum discharge volume.
- 

---

## NOTICE

---

- The presented values are theoretical and may differ slightly from the actual values depending on the working conditions.
- 

Spacers Thickness	0 ~ 3mm ~ 6mm
Discharge Volume	0.8ml ~0.6ml~0.4ml

---

---

## NOTICE

---

- 1.You can change output volume or pressure by insert or remove spacers.
  - 2.Need to make sure the plug is tightened after adjusting the output volume or pressure.Loosening plug can cause damage to seal.
- 

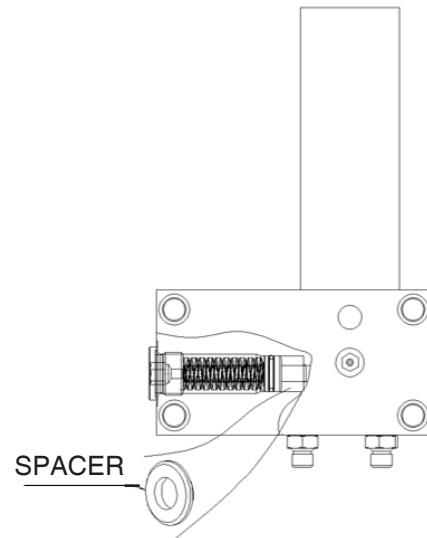

# Disassembly and Installation of Breaker

## Breaker's Disassembly

Breaker's status before disassembly.

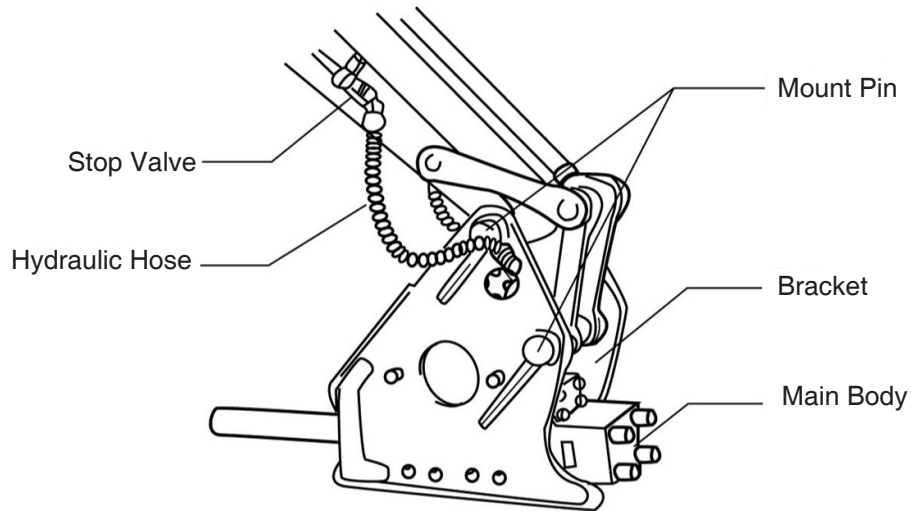

Closed the stop valve.

Take hose off from arm pipe, and inserting plug to prevent sundries drop in main body and piping.

Remove two mount pins from breaker bracket.

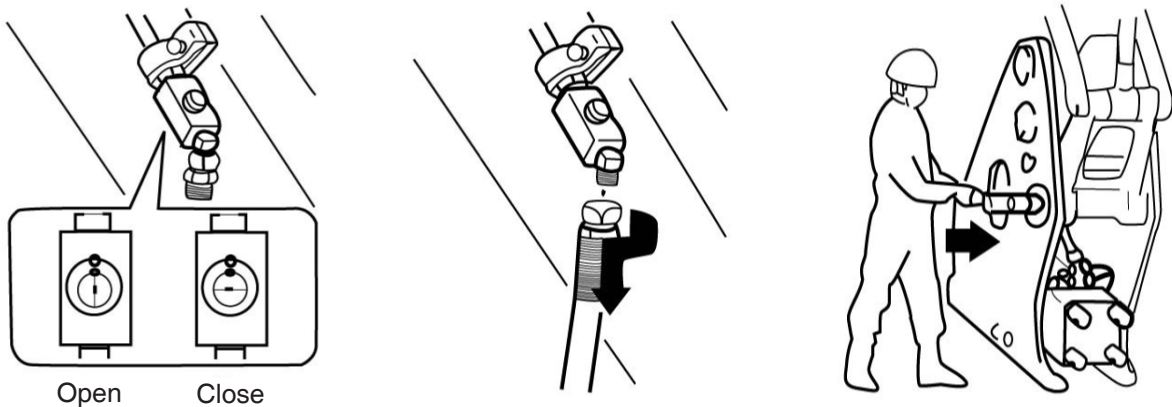

# Disassembly and Installation of Breaker

## Breaker's Disassembly

Lift up the arm slowly, take off hydraulic breaker.

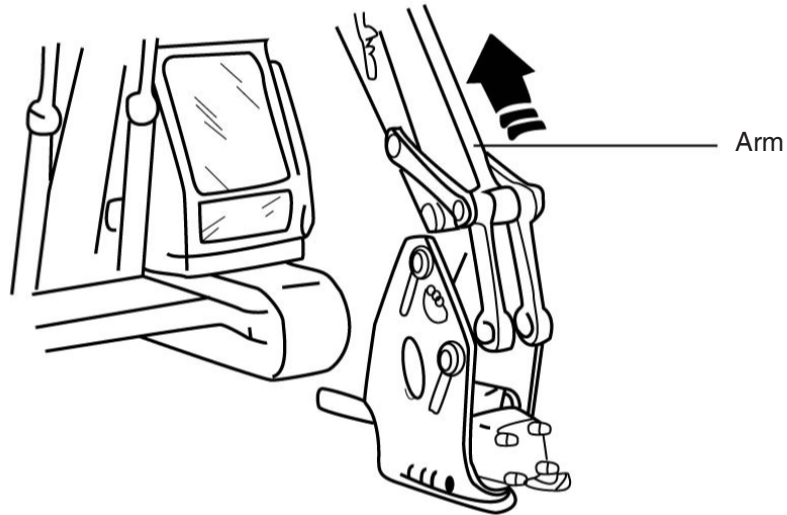

---

## IMPORTANT

---

- To avoid sundries or others drop in main body, please must tighten the plug of hose and pipe.
-

# Disassembly and Installation of Breaker

## Breaker's Installation

1. Make the center of bracket aimed to the center of arm, then put down the arm slowly, and install mount pin.
2. Install mount pin at arm side, and operate bucket cylinder, then install the mount pin at link side.
3. Take off plugs on each pipe and hose, then connect them.
4. Open the stop valve .

---

## IMPORTANT

---

- When make the center of bracket aimed to the center of arm, engine's rotating speed should be reduced , to make boom's working speed slow down.
- 

## Breaker Maintenance

If breaker will be unused for more than one week, please follow below method.

1. Hose, pipe must be installed plugs.
2. Release the nitrogen from nitrogen chamber.(refer to P32, "nitrogen chamber pressure adjustment" )
3. Remove chisel from breaker.
4. Make hammer aim to the end of piston, and impact it to make piston go back.
5. Apply grease into Front Head.(refer to P41 'Maintenance')

---

## IMPORTANT

---

- In order to protect breaker, please place it in room, or place it on sleepers, and covered by tarpaulin(to prevent rain).
  - If remove hose plug, piston will be easily draw back.
- 

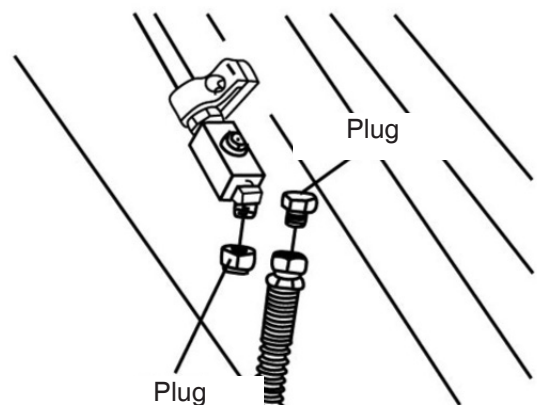
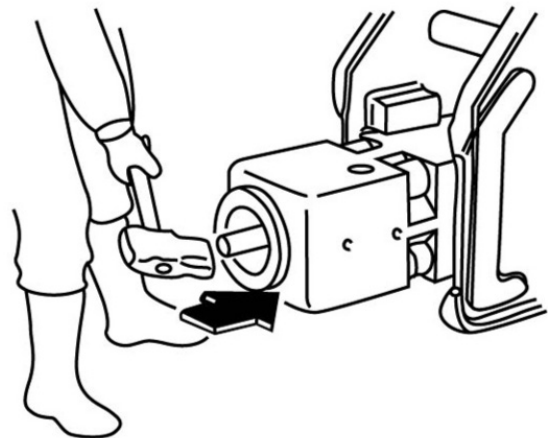



# Tool

Please use original DOOSAN tools only

Moil, Conical type

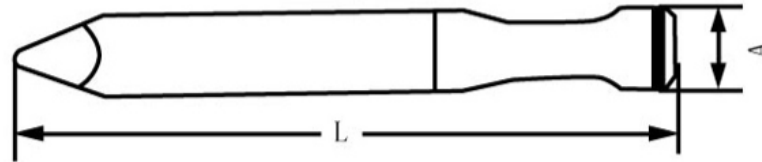

Flat type

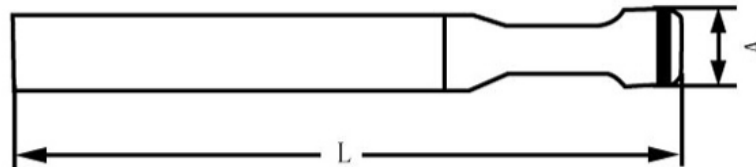

## Tool Dimension

Form 9

Unit:mm

Item \ Model	HB01	HB02	HB03	HB04	HB06	HB08	HB15	HB20	HB22
	(S/T/H)	(S/T/H)	(S/T/H)	(S/T/H)	(S/T/H)	(S/T/H)	(S/T/H/FH)	(S/T/H/FH)	(S/T/H/FH)
Diameter(A)	40	45	45	53	68	75/80	100	135	140
Length(L)	430	500	500	580	702	755	1055	1200	1300
Front Cover(B)	40	45	45	53	68	80	100	135	140

Item \ Model	HB30	HB32
	(S/T/H/FH)	(S/T/H/FH)
Diameter(A)	150	155
Length(L)	1300	1500
Front Cover(B)	150	155

## Tool Type and Application

Sketch Map	Type	Application
	Conical Point (C)	Concrete
	Moil Point (M)	Rock
	H-Wedge (H)	Trenching
	V-Wedge (V)	Finishing
	Blunt (B)	Rock

We're not responsible for the failures of hydraulic breakers caused by non original DOOSAN tools.

## Replacement of Tool

1. Set the breaker on clean and level ground, clean the hole of Stop Pin, and remove the Stop Pin with pin bar in the opposite side of Rubber Plug.

**NOTE:** When removing Stop Pin, Rod Pin may fall down. Take care not to get injury.

2. Remove the Rod Pin with pin bar from underneath, take Tool out of breaker.
3. Before installing Tool, apply heat-resisting grease onto groove of Tool. And then install the Tool in reverse order of removal.
4. Change the face of Rod Pin regularly to avoid excessive deformation.

**NOTE:** Check the Rod Pin if there's any broken or wear regularly.

5. The Tool should be replaced after wearing. Please refer to the reject dimensions as per below.

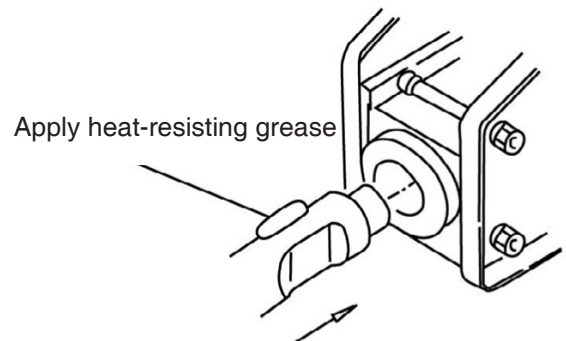
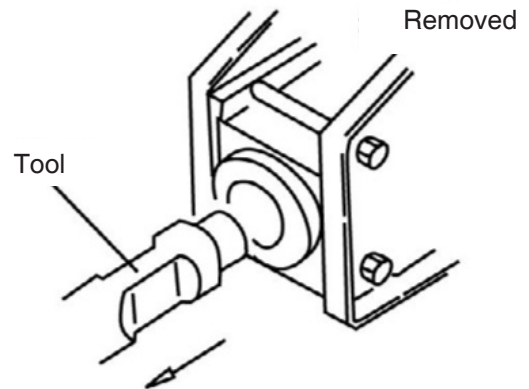
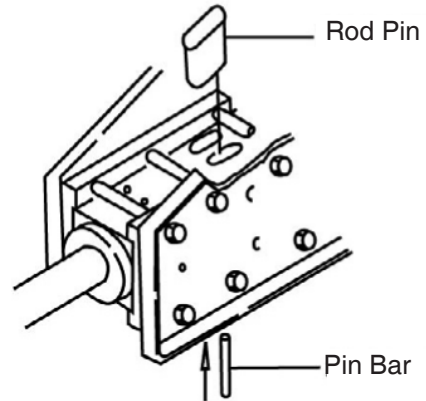
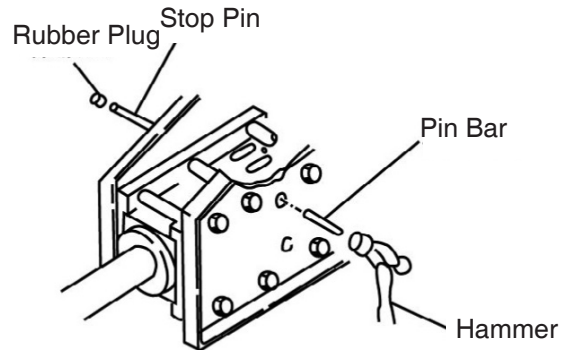

---

### **WARNING**

---

- When remove or install Tool, please pay attention to its weight.
  - Knocking the tips of Tool is forbidden.
  - Inserting hands into Main Body is forbidden.
  - Do not stand near to the Tool when connecting hydraulic hoses or charging gas into Back Head, as the Tool may come out suddenly.
  - Do not touch Tool with hands after breaker stops working, as the temperature of Tool may be very high.
-

## Replacement of Tool

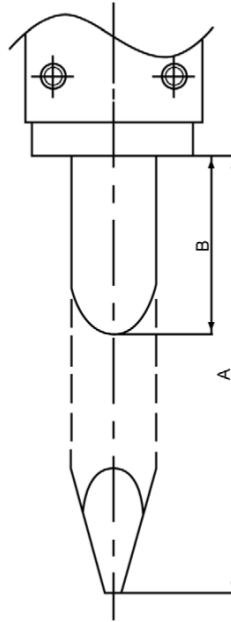

Form 10

Unit:mm

No.	Model	Original Length (A)	Reject Length (B)
1	HB01 (S/T/H)	297	200
2	HB02 (S/T/H)	326	200
3	HB03 (S/T/H)	326	200
4	HB04 (S/T/H)	330	200
5	HB06 (S/T/H)	425	250
6	HB08 (S/T/H)	427	250
7	HB15 (S/T/H/FH)	561	250
8	HB20 (S/T/H/FH)	762	400
9	HB22 (S/T/H/FH)	762	400
10	HB30 (S/T/H/FH)	777	400
11	HB32 (S/T/H/FH)	913	500

# Replacement of Rod Pin

1. If Rod Pin is excessively deformed, it will be difficult to replace Tool. Therefore, after operating the breaker every 100 to 150 hours, change the face of Rod Pin which comes in contact with Tool. (Each face of Rod Pin can be used).
2. When repairing Rod Pin, check if there's any bend or deformation.
3. After grinding the worn area of Front Cover and Rod Pin, replace Tool.

When changing the face of Rod Pin, put the Rod Pin into the groove of Tool and lock it with Stop Pin.

4. The Rod Pin should be replaced after wearing. Please refer to the reject dimensions as below.

If there's any wear or bend, firstly grind it with grinder.

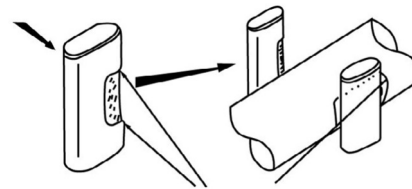
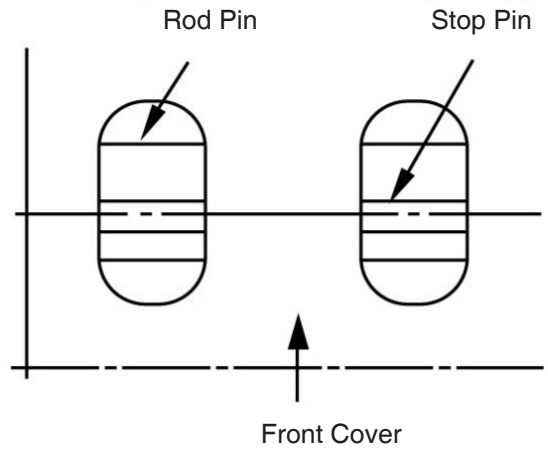

Form 11

Unit:mm

No.	Model	Original Length (A)	Reject Length (B)
1	HB01(S/T/H)	28	26
2	HB02(S/T/H)	28	26
3	HB03(S/T/H)	28	26
4	HB04(S/T/H)	28	26
5	HB06(S/T/H)	38	36
6	HB08(S/T/H)	38	36
7	HB15(S/T/H/FH)	60	57
8	HB20(S/T/H/FH)	80	77
9	HB22(S/T/H/FH)	89.5	85.5
10	HB30(S/T/H/FH)	89.5	85.5
11	HB32(S/T/H/FH)	96	92

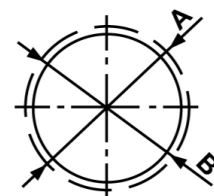
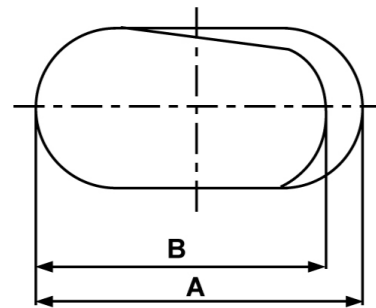

B is the minimum width after worn

## Replacement of Front Cover

1. If the clearance between Tool and Front Cover is too big, it could shorten the life of Piston and Tool, even cause the breakage of Tool and Piston.

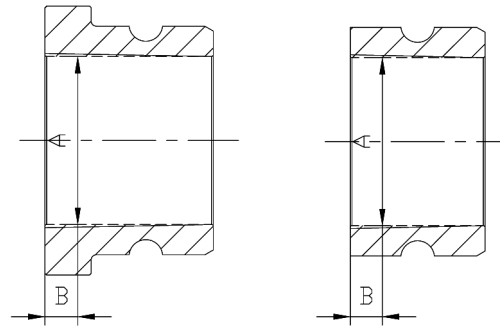

Front Cover(Side/Top)      Front Cover(Box)

If the clearance between Tool and Front Cover is too big, it could cause following problems,

1. It could cause irregular impact between Piston and Tool, it will shorten the life of Piston.
2. It could cause angle of inclination and it may lead to breakage of Tool.

The Front Cover should be replaced after wearing. Please refer to the reject dimensions as per below.

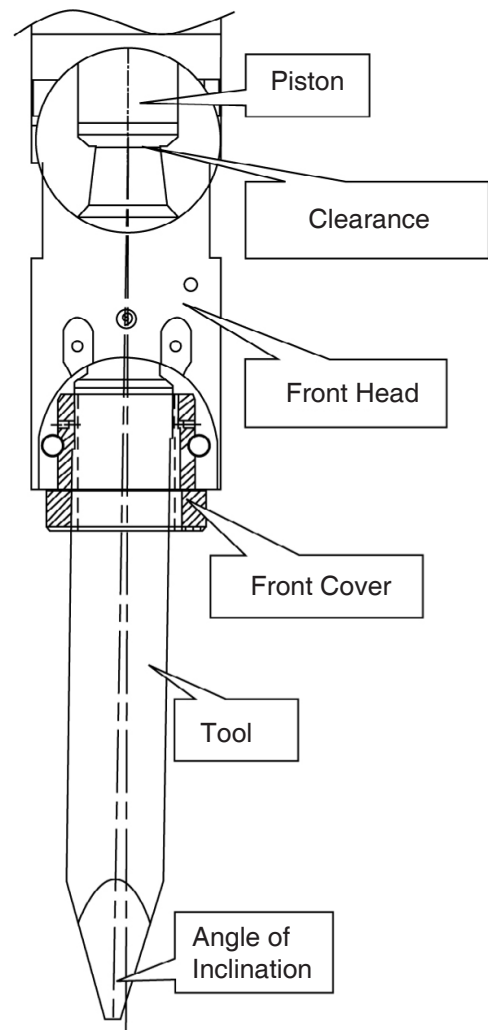

Form 12

Unit:mm

No.	Model	B	Original A	Rejected A
1	HB01(S/T/H)	10	40	43
2	HB02(S/T/H)	10	45	48
3	HB03(S/T/H)	10	45	48
4	HB04(S/T/H)	10	53	56
5	HB06(S/T/H)	10	68	72
6	HB08(S/T/H)	10	75/80	80/85
7	HB15(S/T/H/FH)	10	100	105
8	HB20(S/T/H/FH)	10	134.5	140.5
9	HB22(S/T/H/FH)	10	140	146
10	HB30(S/T/H/FH)	10	150	156
11	HB32(S/T/H/FH)	10	155	161

## Replacement of Ring Bush

1. If the clearance between Tool and Ring Bush is too big, it could shorten the life of Piston and Tool, even cause the breakage of Tool and Piston.
2. Once A or C meets the Rejected Dimension in below form, the Ring Bush must be replaced immediately.

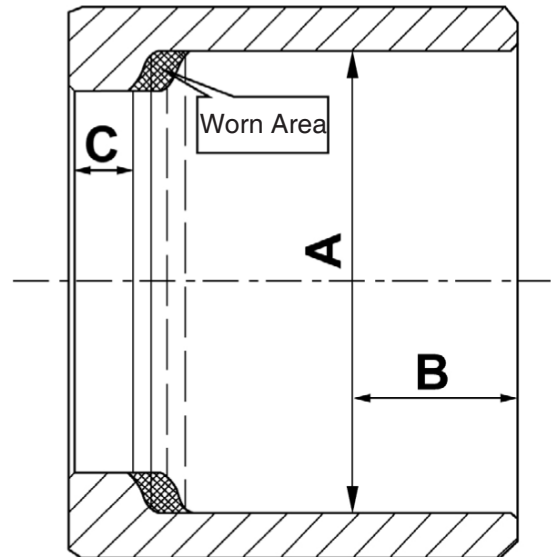





Form 13

Unit:mm

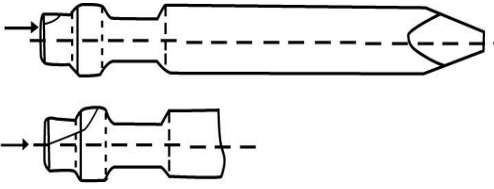
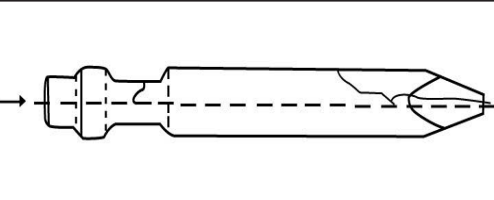
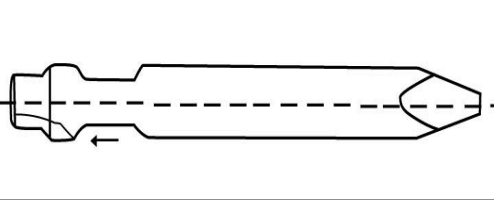

No.	Model	Measure at B	Original Dia. A	Rejected Dia. A	Original Height C	Rejected Height C
1	HB01 (S/T/H)	10	40	42	8.75	6
2	HB02 (S/T/H)	10	45	47	10.25	8
3	HB03 (S/T/H)	10	45	47	10.25	8
4	HB04 (S/T/H)	10	53	55	8.5	6
5	HB06 (S/T/H)	12	68	71	10.5	8
6	HB08 (S/T/H)	12	75/80	78/83	18	15
7	HB15 (S/T/H/FH)	15	100	104	17	14
8	HB20 (S/T/H/FH)	18	135.5	140	29	26
9	HB22 (S/T/H/FH)	15	140	145	40	36
10	HB30 (S/T/H/FH)	20	150	155	32.5	29.5
11	HB32 (S/T/H/FH)	15	155	160	46	42

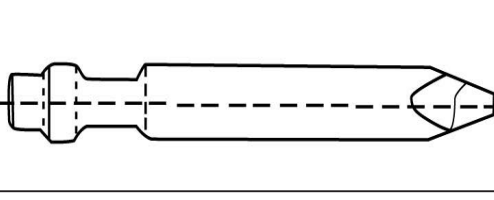
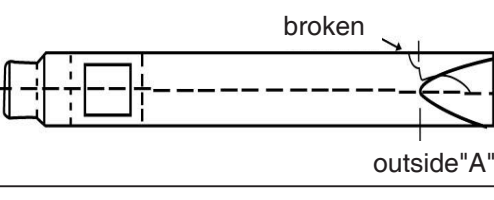
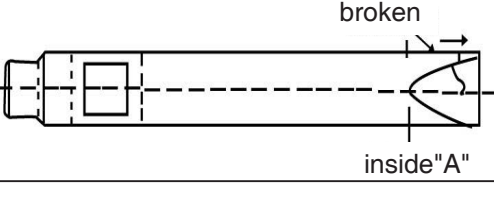
# Warranty of Tool

## Warranty Standard of Tool



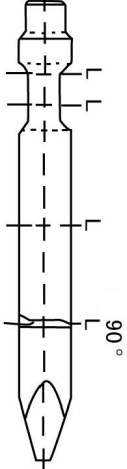
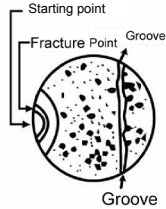

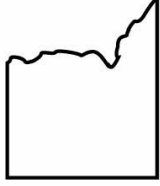
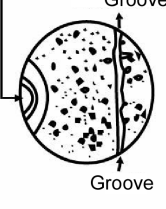
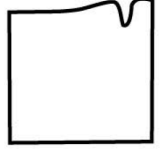
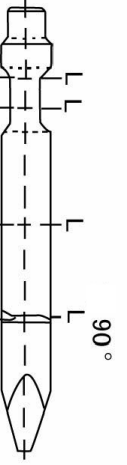
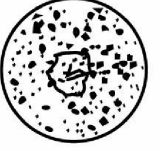
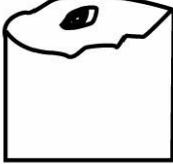
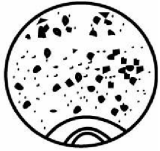
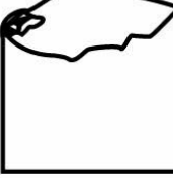
NO.	Damage State	Warranty	Damage Reason & Contents
a		Free for compensation	Bad heat treatment: fracture from outside of tool centerline
b		Free for compensation	Bad material: fracture from tool centerline
c		Chargeable (not compensable)	Damage and wear caused by blank firing
d		Chargeable (not compensable)	<ul style="list-style-type: none"> <li>• Inner parts wear off for continuous blank firing ( eg. rod pin )</li> <li>• wear occurs when strike force reaches rod pin during blank firing</li> </ul>
e		Chargeable (not compensable)	wrong operating method: waging from side to side when plugged into object, leveraged operating or not vertical tool operating
f		Free for compensation	<ul style="list-style-type: none"> <li>• Bad material or heat treatment</li> <li>• Damage reach into line A</li> </ul>
g		Chargeable (not compensable)	<ul style="list-style-type: none"> <li>• Bad choice of tool and operating method</li> <li>• Damage reach into line A</li> </ul>
h		Chargeable (not compensable)	<ul style="list-style-type: none"> <li>• Wrong operating method</li> <li>• Heat produced from prolonged strike (more than one minute) of unbreakable ground makes tool material soft and tool mushroom-like</li> </ul>

# Warranty Assurance Standard Based on Fracture Face

NO.	Damage State	Fracture Face of Tool	Warranty	Reason of Fracture	
a				Chargeable (not compensable)	<ul style="list-style-type: none"> <li>wrong operating method: waging from</li> <li>side to side when plugged into object or leveraged operating method</li> <li>overbending of tool etc.</li> </ul>
				Chargeable (not compensable)	<ul style="list-style-type: none"> <li>improper maintenance and operating method</li> <li>insufficient lubrication</li> <li>trace of deep scratch occurs where fracture begins</li> </ul>
				Chargeable (not compensable)	<ul style="list-style-type: none"> <li>wrong operating method: waging from side to side when plugged into object or leveraged operating method</li> <li>concave</li> <li>occurs at the fracture part and round</li> <li>mark occurs where fracture begins</li> </ul>
b				Free for compensation	<ul style="list-style-type: none"> <li>bad material</li> <li>fracture occurs from the centre of tool</li> </ul>
				Free for compensation	<ul style="list-style-type: none"> <li>bad material</li> <li>bad heat treatment</li> </ul>

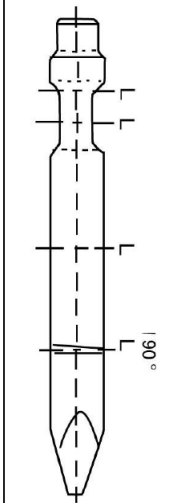

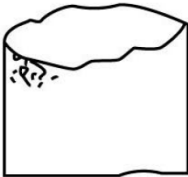
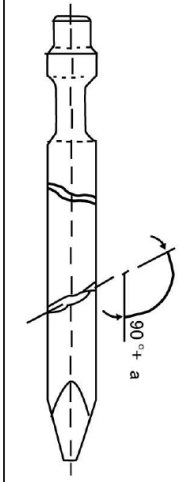
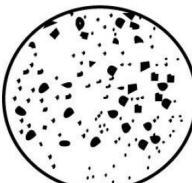
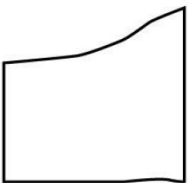
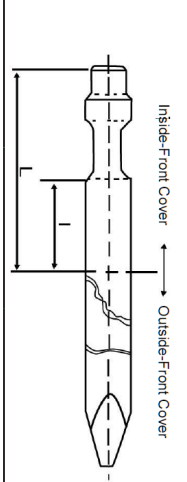
# Warranty Assurance Standard Based on Fracture Face

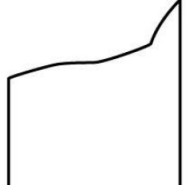
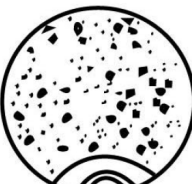
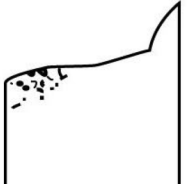
NO.	Damage State	Fracture Face of Tool		Warranty	Reason of Fracture
c				Chargeable (not compensable)	<ul style="list-style-type: none"> <li>• tool wags from side to side when plugged into object or leveraged operating method or foreign matter sinks in or insufficient oil injection</li> <li>• defect or scratch from tool surface develops into inner fracture of tool</li> </ul>
d				Chargeable (not compensable)	<ul style="list-style-type: none"> <li>• improper operating method: waging from side to side when plugged into object or leveraged operating</li> <li>• fracture occurs by way of tilting from centerline(90+a)</li> </ul>
e				Chargeable (not compensable)	improper operating method: waging from side to side when plugged into object or leveraged operating
				Free for compensation	<ul style="list-style-type: none"> <li>• bad material and bad heat treatment</li> </ul>
				Chargeable (not compensable)	<ul style="list-style-type: none"> <li>• improper maintenance and operating method</li> <li>• surface defect develops into deep of tool</li> <li>• fracture caused by serious surface defect of tool (eg. Scratch)</li> </ul>

# Gas Charging & Adjustment

## Adjustment the pressure of nitrogen chamber

1. Under the normal temperature, the normal pressure range of the nitrogen is as showing in form.
2. The proper pressure of the breaker is already been adjusted when delivered from the factory, but still have to check the pressure before use.
3. The gas pressure should be checked once every two weeks.

## The method of checking the gas pressure

1. Take off the plug counter clock wise, Tighten the three-way valve clockwise, Tighten the nitrogen gauge nut, close the relief valve.
2. Press down the switch on the three-way valve with your hand and read the nitrogen meter.
3. If the nitrogen is excessive, release the nitrogen from the overflow valve of the three-way valve to make the nitrogen be standard.

## The method of charging the gas nitrogen

1. Repeat the method of checking the gas pressure 1 and 2.
2. If the nitrogen is less, connect the high pressure hose of nitrogen to the high pressure hose interface of the nitrogen meter and the interface of the nitrogen bottle.
3. Press the switch of the three-way valve down, turn on the switch of the nitrogen bottle slowly counterclockwise until the pressure of the nitrogen gauge to be normal.
4. Three times of charging and three times of release to ensure the purity of nitrogen.

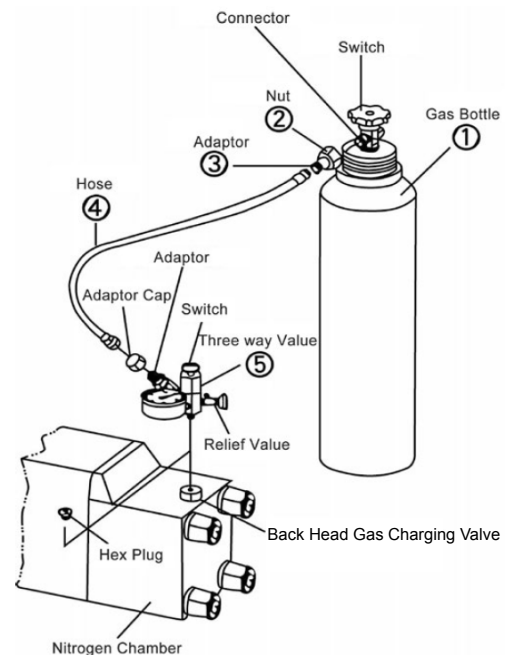
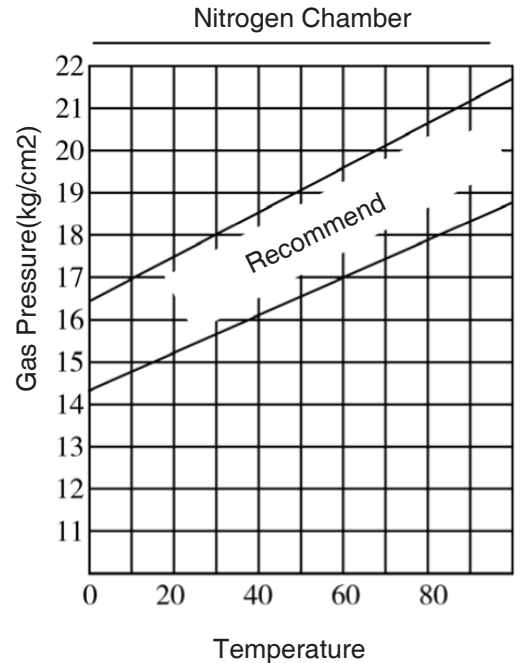

# Gas Charging & Adjustment



## WARNING

- Do not remove the through bolts before release Nitrogen of back head.
- Only use the pure nitrogen, other air could cause the breaker work abnormally.
- The pressure of the gas nitrogen refer to the instruction manual.
- The gas pressure should be checked once every two weeks, change it if necessary.

## Set the pressure range of Nitrogen chamber accumulator Relief valve

Form 14

Unit:kg/cm<sup>2</sup>)

Item \ Model	HB01 HB02 (S/T/H)	HB03 (S/T/H)	HB04 HB06 (S/T/H)	HB08 (S/T/H)	HB15 (S/T/H/FH)	HB20 (S/T/H/FH)	HB22 (S/T/H/FH)	HB30 (S/T/H/FH)	HB32 (S/T/H/FH)
The pressure of the nitrogen chamber	16.5	16.5	16.5	16.5	16.5	6	16.5	6	16.5
The pressure of the accumulator						55~60	55~60	55~60	55~60
The pressure of the relief valve	130~140	130~140	150~160	160~180	180~200	220	220	220	220

## The adjustment of accumulator pressure

The normal range of accumulator pressure at the normal temperature is as the form.



## WARNING

- Do not remove the accumulator cover before the accumulator is deflated.
- Only use the pure nitrogen, other air could cause the breaker work abnormally.
- The charging pressure:55-60bar.
- The gas pressure should be checked once a week, contact the dealer if necessary.

# Gas Charging & Adjustment

## The method of checking the gas pressure(As showing of the drawing)

1. Turn the plug (9) on the accumulator counterclockwise, tighten the nitrogen meter clockwise, tighten the nut of nitrogen meter, close the relief valve.
2. Turn the accumulator nut (11) counterclockwise, Turn the inflatable valve counterclockwise until the pointer of the nitrogen meter move, check the nitrogen meter.
3. If the nitrogen is excessive, release the nitrogen from the relief valve of the nitrogen meter to make the nitrogen be standard.
4. Turn the inflatable valve clockwise and tighten the nut(11).

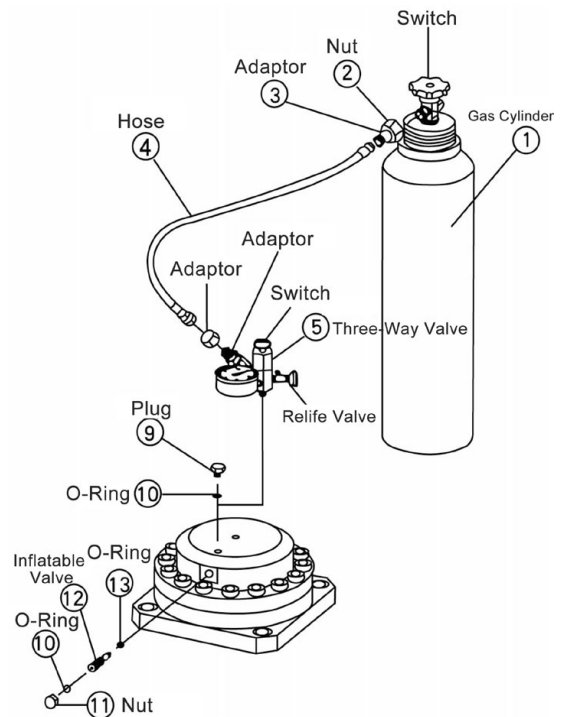

## The method of charging the gas nitrogen(as showing of the drawing)

1. Repeat the method of checking the gas pressure 1 and 2.
2. If nitrogen is less, connect the hose of nitrogen to the connector of the nitrogen meter and the gas cylinder(As showing of the drawing)
3. Turn on the switch of the gas cylinder slowly counterclockwise until the pressure of the nitrogen gauge to be normal.
4. Turn off the inflatable valve clockwise, tighten the nut.

Nitrogen Chamber

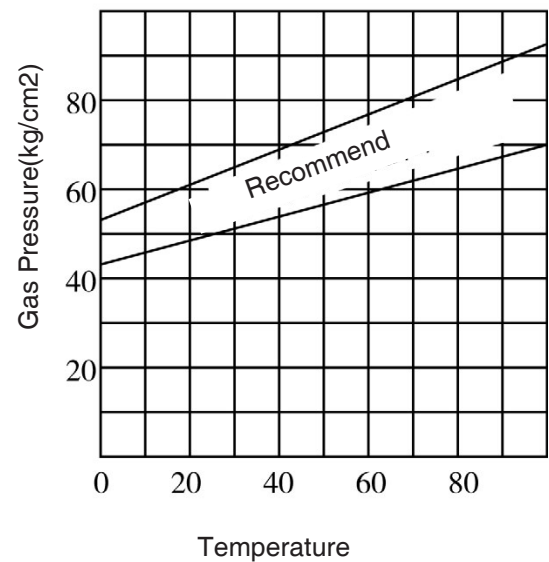

## IMPORTANT

- When you replace two or more through bolts or disassemble the breaker, you should release the nitrogen of the nitrogen chamber.

# Maintenance

Form 15

Unit:mm

Checking	Checking before Operation	Regular Checking	Remarks
Whether the nuts are loose	Every Day	Every Day	
Whether the hydraulic oil is dirty, and enough	Every Day	Every Day	
Whether the oil is leaked	Every Day	Every Day	
Whether the hydraulic hoses are damaged	Every Day	Every Day	
Injecting lubricating grease	Every Day	Every Day	
Whether the chisel and rod pins are damaged	Every Day		
The pressure of Nitrogen chamber	once every two weeks	once every two weeks	
The pressure of Accumulator	once a month	once a month	Form 8

## All bolts and Nuts

Before working, please check whether the nuts are loose. If the nuts are loose, it will influence the normal work of bolts, so that it will cause abnormal operation of hydraulic breaker. Besides, please tighten them according to specified torque regularly.

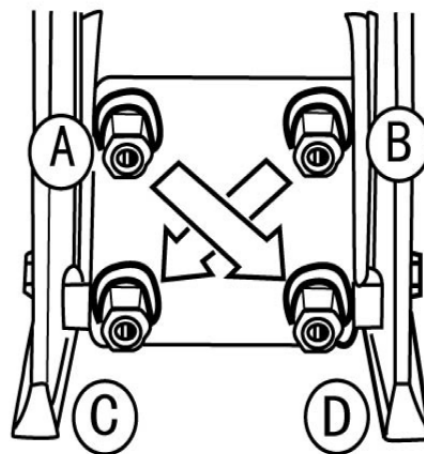

(A-D/B-C)

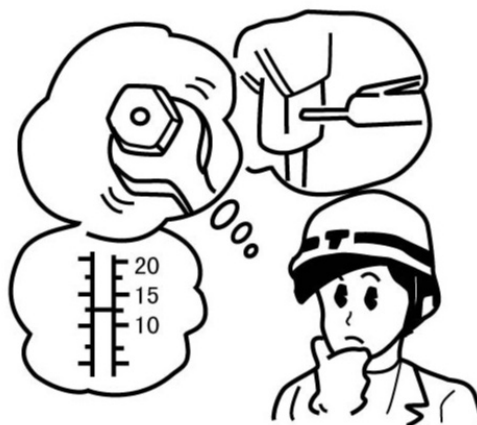

# Maintenance

Form 16

Unit:N.m

Bolt and Plug Torque					
Bolt Size	Tool Size (mm)	Frist Torque	Second Torque	Breaker Type	Note
M22XP1.5	30	263	350	HB03/HB02	Through Bolt
M24XP2.0	36	300	400	HB04	
M27XP2.0	41	375	500	HB06	
M30XP2.0	46	637.5	850	HB08	
RD39XP3.0	55	1500	2000	HB15	
RD42XP4.233	65	1875	2500	HB20	
RD52XP3.175	75	2200	3000	HB22	
RD48XP4.233	70	2100	2800	HB30	
RD56XP3.175	75	3200	4500	HB32	

Form 17

Unit:N.m

Bolt Size	Tool Size (mm)	Torque	Note1	Note2
M16XP1.5	24	270		Valve Adjust Nut
M18XP1.5	27	300		
M20XP1.5	30	300		
M22XP1.5	34	300		
M24XP2.0	36	350		
M27XP1.5	46	600		
M33XP2.0	55	700		
PF 1	41	350	Thread glue	Valve Plug
PF 1 1/4	50	1000	Thread glue	
PF1/2-PF1/2	27	200		Adapter
PT3/4-PF3/4	36	280		
PF3/4-PF3/4	36	280		
PT1-PF1	40	350		
PF1-PF1	40	350		
PF 1 1/4-PF1	50	350		
PF 1 1/2-PF1	55	350		
PT 1 1/4-PF1 1/4	55	350		
PF 1 1/2-PF1 1/4	55	350		
PF1/2	27	200		Acc. Plug/ Nitrogen injection/ Breath valve
PF7/8	41	300		
M10XP1.0	19	62		
M12XP1.25	22	105		
M16XP1.5	30	170		
M20XP2.0	41	400		

# Maintenance

Form 18

Unit:N.m

Side Bolt And Nut					
Bolt Size	Tool Size (mm)	Frist Torque	Second Torque	Breaker Type	Note
M20XP2.5	30	345	520	HB04/HB02/HB03	
M27XP2.0	41	750	1000	HB06/08	
M36XP3.0	55	1000	1500	HB15	
RD48XP3.175	75	2250	3000	HB20/22/30	
RD56XP3.175	85	3375	4500	HB32	
M14	21	150	200	HB03/04	Link Flange Bolt
M20	30	390	520	HB06/08/15	
M24	36	600	900	HB20/22	
M30	46	1000	1500	HB30/32	

Form 19

Unit:N.m

Side Bolt And Nut					
Bolt Size	Tool Size (mm)	Frist Torque	Second Torque	Breaker Type	Note
M10	16L	42	60	HB06/08	Cover Bolt
M14	12L	75	100	HB15	
M20	17L	350	400	HB20 And Up	
<b>Note: One bolt should be tightened by one time, more than one bolts should be tightened by two steps.</b>					

# Maintenance

## Checking whether the rod pins are damaged

If the rod pins are damaged, the chips will be stuck in the surface of piston or cylinder when the hydraulic breaker is working. Please make sure to check it before operation.

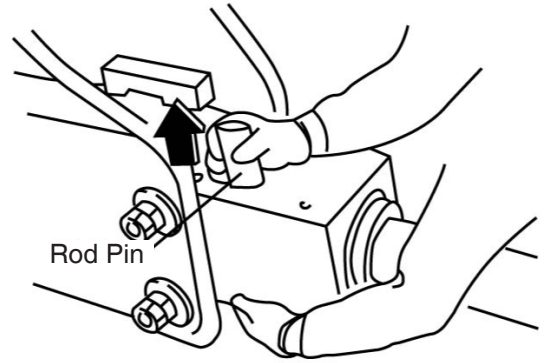

## Chisel and Rod Pins

If the pressure is not enough, or the working objects are fragile when the breaker is working, the chisel and rod pins will be deformed and expanded. During inspection, please use grinding wheel to polish in order to eliminate the expanding parts, or use the rod pin in return.

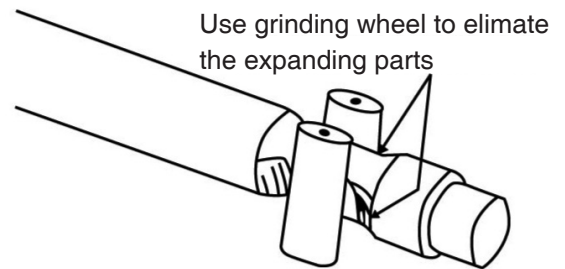

## Chisel and Front Cover

If the gap between chisel and front cover is oversized, it will cause eccentric wear of piston and chisel, and lead to their unsteady contact, furtherly cause the damage of piston and chisel, and the chisel turn fragile. When the gap is oversized, the front cover must be changed. Detailed standards of replacement are as follows:

### Form 20

Model	Gap A (mm)
HB01 (S/T/H) - HB04 (S/T/H)	≥ 5
HB06 (S/T/H) - HB08 (S/T/H)	≥ 6
HB15 (S/T/H) - HB70 (S/T)	≥ 8

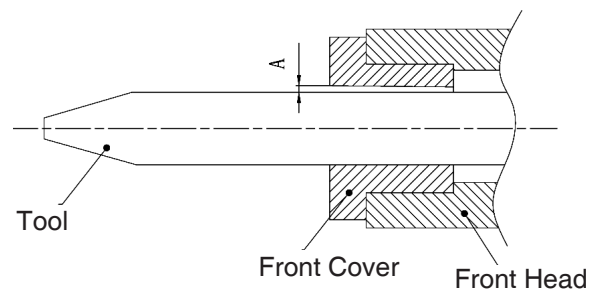



# Maintenance

## Injecting Lubricating Grease

Before working or every two hours: Push chisel into front head, inject lubricating grease from the grease nipple. Referred injection is 5-20 times. The bigger model, the more injection.

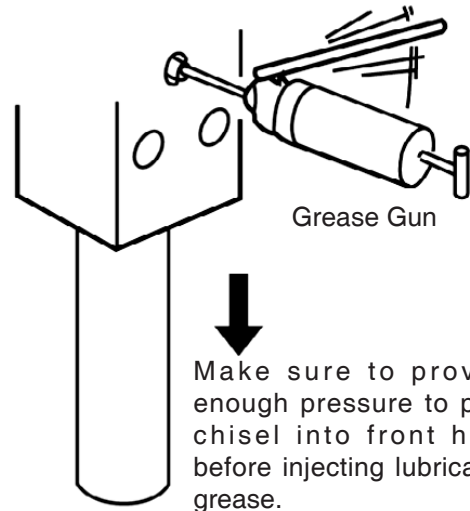

---

## IMPORTANT

---

- **Be sure to make hydraulic breaker standing, and push chisel into front head before injecting lubricating grease to prevent the grease to enter the piston impact chamber.**
  - **Please use lithium grease.**
- 

## Hydraulic oil

Check the hydraulic oil capacity in oil tank timely, Please replenish the oil in time if it is insufficient. Please keep the hydraulic oil clean.

If the hydraulic oil is polluted, it will cause the impeded working of valve and do harm to the breaker.

---

## IMPORTANT

---

- **Please use the same hydraulic oil produced by one company, if different oil is mixed, chemical reaction may be set off.**
-

# Maintenance

## Oil leakage

Check the main body of breaker, accumulator and pipe kits of hydraulic oil to find whether there's any leakage or not.

It is normal that oil leak slightly at the connecting parts between front head and chisel, it lubricates chisel.

If the breaker leak oil, please replace the O-ring and/or oil seal on the leaking parts.

Please replace oil seal(s) by following procedures below:

1. Apply lubricating oil on seal retainer, oil seal and other needed parts.
2. Put O-ring in the groove inside seal retainer.
3. Fold oil seal by hand (as shown in the figure 1), please note not to fold too much to break the oil seal.
4. Put the oil seal in the groove inside the seal retainer, push the folded part from inside to make it recover (as shown in the figure 2).

1

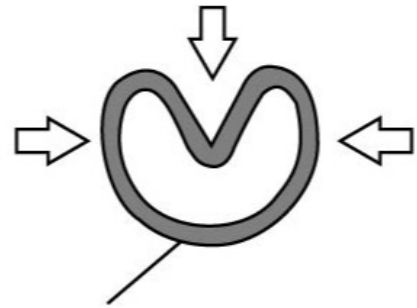

Step Seal

2

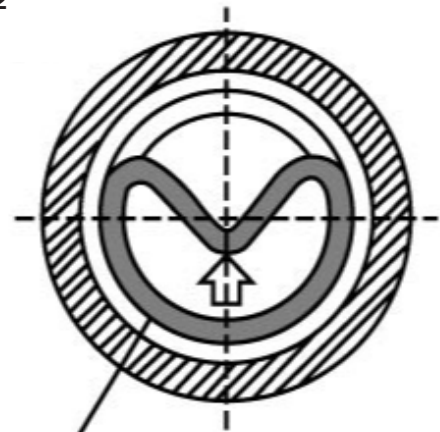

Step Seal

---

## IMPORTANT

---

- If oil seals is broken, please check carefully whether there are scratches on surface of cylinder and/or piston.
  - Check carefully to make sure no chips of broken oil seal remain inside of cylinder.
-

# Trouble-Shooting

Please check again before the breaker is sent to be serviced



- **Warning: Nitrogen gas must be released before disassembling the breaker.**

Symptom	Cause	Required action
Low impact power	<ol style="list-style-type: none"> <li>1.Low engine speed.</li> <li>2.Low nitrogen gas pressure of back head.</li> <li>3.Low nitrogen gas pressure of accumulator.</li> <li>4.Wrong pressure setting or adjustment of relief valve.</li> <li>5.Failure of chisel.</li> </ol>	<ol style="list-style-type: none"> <li>1.Re-adjust engine speed controller.</li> <li>2.Check nitrogen gas pressure, re-fill gas if it is released.</li> <li>3.Check nitrogen gas pressure, re-fill gas if it is released.</li> <li>4.Re-set or re-adjust pressure of relief valve.</li> <li>5.Smoothen the scored parts of chisel, front cover and ring bush by using abrasive paper or grinder.</li> </ol>
No blow out	<ol style="list-style-type: none"> <li>1.Wrong pressure adjustment of relief valve.</li> <li>2.Excessive nitrogen gas pressure of back head.</li> <li>3.Hydraulic oil in back head injection.</li> <li>4.Scoring of piston, cylinder or valves.</li> <li>5.Faulty hydraulic hose connection.</li> <li>6.Stop valve(s) closed.</li> <li>7.Lack of hydraulic oil.</li> </ol>	<ol style="list-style-type: none"> <li>1.Re-adjust valve adjuster. (see attached form 4)</li> <li>2.Re-adjust nitrogen gas pressure in back head. (see attached form 4)</li> <li>3. Replace Gas Seal.</li> <li>4.In case of a slight scratch, smoothen the scored surface by using abrasive paper or grinder. Replace the damaged part(s) if needed.</li> <li>5.Reconnect hydraulic hose.</li> <li>6.Open stop valve(s).</li> <li>7.Fill hydraulic oil.</li> </ol>

# Trouble-Shooting

Symptom	Cause	Required action
Irregular impact	<ol style="list-style-type: none"> <li>1.Excessive nitrogen gas pressure of back head.</li> <li>2.Low hydraulic oil pressure.</li> <li>3.Scoring of chisel and/or front cover.</li> <li>4.Scoring of piston, cylinder or valve(s).</li> <li>5.Excessive pressure of hydraulic oil returning hose.</li> <li>6.Excessive temperature of hydraulic oil.</li> <li>7.Low pressure of relief valve.</li> <li>8.Lack of hydraulic oil.</li> </ol>	<ol style="list-style-type: none"> <li>1.Release gas till standard pressure.</li> <li>2.Re-adjust pressure of relief valve.</li> <li>3. In case of a slight scratch, smoothen the scored parts of chisel and front cover by using abrasive paper or grinder. Replace the damaged part(s) if needed.</li> <li>4. In case of a slight scratch, smoothen the scored surface by using abrasive paper or grinder. Replace the damaged part(s) if needed.</li> <li>5.Check filter element and cooler, clean or replace the unit.</li> <li>6.Clean or replace cooler, or replace hydraulic oil in higher viscosity.</li> <li>7.Re-adjust pressure of relief valve till standard pressure.</li> <li>8.Fill hydraulic oil.</li> </ol>
Gas leakage (rapidly leaking is abnormal) <ol style="list-style-type: none"> <li>1.Gas leaking from gas charging valve.</li> <li>2.Gas leaking from adjuster valve.</li> <li>3.Gas leaking from the connecting surface between cylinder and back head.</li> <li>4.Gas leaking from gas seal.</li> </ol>	<ol style="list-style-type: none"> <li>1.O-ring for charging valve is damaged.</li> <li>2.O-ring for adjuster valve is damaged.</li> <li>3.Looseness of through bolt.</li> <li>4.Gas seal is damaged. (After plucking out oil returning hose, if bubbles can be found in hydraulic oil, it means the gas seal is damaged)</li> </ol>	<ol style="list-style-type: none"> <li>1.Replace.</li> <li>2.Replace.</li> <li>3.Tighten.</li> <li>4.Replace.</li> </ol>

# Note

Version: 2022.08.24